

ECT [DIN] 2-Wire Isolator, Converter, and Repeater in an Aluminum Housing



Table of Contents

Introduction	1
Specifications & Ordering Information	2-3
Input-Loop Powered	2
Output-Loop Powered	3
Calibration	4
Calibration Setup	4
Calibration Diagrams	5
Calibration Procedure	6
Installation	7
Electrical Connections	7
Installation Diagrams	7-8
Customer Support	8

Introduction

This is the users' manual for Moore Industries' line of 2-wire, Economy Signal Isolators and Converters, the ECT [DIN]. Available in configurations that accept a variety of inputs, the principal function of the ECT family of products is to provide low cost isolation (up to 1500Vrms) between instruments at either end of a process loop.

Additionally, some ECT configurations perform signal conversion. They accept either dc or ac voltages and provide a precise, industry-standard 4-20mA output.

The ECT is a highly cost-effective means of protecting process signals from distortions associated with ground loops, motor noise and other common types of ambient electrical interference.

Options

There are several options available for the ECT:

- **EM – Externally Mounted Transformer**, for use with the 0-5Aac input configuration, this option consists of a toroidal transformer that physically separates high-level current input from the receiving device in a process loop. This provides the added convenience of allowing the servicing of receivers without having to interrupt process signals.
- **RF – RFI/EMI Protection**, available for use with our new aluminum housings, this option provides you with outstanding protection against RFI and EMI interference. (requires -EM option for ac current input). With this option, the ECT will not be affected by more than $\pm 0.1\%$ of span at 30 V/m @ 20-1000Mhz.

Figure 1. The ECT is available in a variety of configurations that accept a myriad of inputs and outputs.

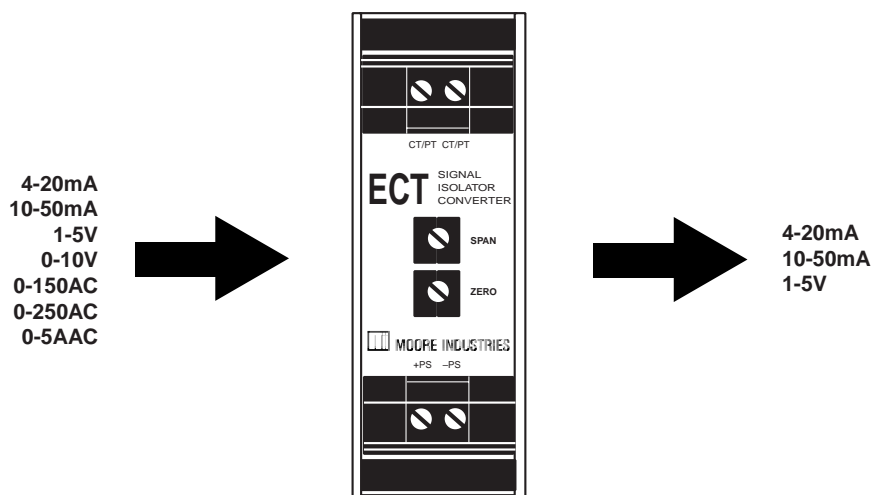

Specifications

2-Wire, Input-Loop Powered Models

<p>Performance Accuracy: ±0.075% of span Stability: ±0.2% of reading per year Isolation: 500Vrms between input and output Output Response: 20msec maximum to 99% of output Ripple: 10mV peak-to-peak maximum measured across 250Ω resistor Over-Voltage Protection: 48V, maximum on output; 48V, reverse polarity protection on output Maximum Input Overrange: 200% of full scale Output Current Limiting: 30mA with 250Ω output load</p>	<p>Performance (continued) Burden: 5.5 Volts when outputs are shorted for 4-20mA inputs, 10.5V with 250Ω load (Output load voltage is reflected on input. Output should be trimmed for anticipated output load)</p> <p>Ambient Conditions Operating Range: -29°C to +82°C -20°F to +180°F Storage Range: -40°C to +85°C (-40°F to +185°F) Ambient Temperature Effect: ±0.018% of span/°C; ±0.005% of span/°C gain change</p>	<p>Ambient Conditions (Continued) Relative Humidity: 0-95% non-condensing RFI/EMI Immunity: Without –RF option: Less than ±0.1% of span error when tested at 10V/m @ 20-1000MHz With –RF option: less than ±0.1% of span at 30V/m @ 20-1000Mhz Common Mode Rejection: Exceeds 95dB at 60Hz with a limit of 500Vrms</p> <p>Adjustments Type: Front panel pots Trim: ±1%</p> <p>Weight DIN Housing, 145 grams (5 oz)</p>
--	--	--

Ordering Information

Unit	Input	Output	Power	Options	Housing
ECT 2-wire (Input-Loop Powered) Isolator/ Converter	4-20MA into 275Ω	4-20MA into 0-250Ω	Current Loop Excitation at 4mA: 5.5VLP 5.5 volts loop powered with 4-20mA (plus voltage across output load)	–RF Enhanced RFI/EMI filtering provides 30V/m @ 20-1000Mhz protection with less than ±0.1% of span error	DIN Aluminum DIN-style housing mounts on 32mm G-type (EN50035) and 35mm Top Hat (EN50022) rails

When ordering, specify: Unit / Input / Output / Power / Options [Housing]

Model number example: ECT / 4-20MA / 4-20MA / 5.5VLP / –RF [DIN]

Specifications

2-Wire, Output-Loop Powered Models

<p>Performance</p> <p>Accuracy: ±0.1% of span; (±0.2% for 0-150AC inputs) Stability: ±0.2% of reading per year Isolation: Without –RF option: 1500Vrms between input and output; With –RF option: 500Vrms between input and output; Output Response Time: 100msec to 99% of output max for DC inputs; 400msec to 99% of output for AC inputs Ripple: 10mV peak-to-peak maximum measured across a 250 ohm resistor Over-Voltage Protection: 48V, maximum on output; 48V reverse polarity protection on output</p>	<p>Performance (continued)</p> <p>Maximum Input Overrange: 250% of full scale for current inputs; 150% of full scale for DC voltage inputs Burden: 1V maximum with 4-20mA input; 0.01V maximum with 0-5A input; Load Capability: $\frac{V_s - 12V_{dc}}{20mA} = \Omega$ Output Current Limiting: 25mA typical; 30mA max.</p> <p>Ambient Conditions</p> <p>Operating Range: -40°C to +85°C -40°F to +185°F Storage Range: -40°C to +85°C (-40°F to +185°F)</p>	<p>Ambient Conditions (Continued)</p> <p>Ambient Temperature Effect: ±0.007% of span/°C typical; ±0.015% of span/°C max. Relative Humidity: 0-95% non-condensing RFI/EMI Immunity: Without –RF option: Less than ±0.1% of span error when tested at 10V/m @ 20-1000MHz With –RF option: less than ±0.1% of span at 30V/m @ 20-1000MHz Common Mode Rejection: Exceeds 95dB @ 60Hz with a limit of 1500Vrms</p> <p>Adjustments</p> <p>Type: Front panel pots Span: ±10% Zero: ±5% (non-interactive when span is set first)</p> <p>Weight DIN Housing, 145g (5 oz)</p>
--	---	---

Ordering Information

Unit	Input	Output	Power	Options	Housing
ECT 2-wire (Output-Loop Powered) Isolator, Converter, and Repeater	4-20MA into 50Ω 1-5V into 1MΩ 0-10V into 1MΩ 0-150AC into 100KΩ 0-5AAC into 0.002Ω	4-20MA into 600Ω with 24Vdc power supply	12-42DC	–RF Enhanced RFI/EMI filtering provides 30V/m @ 20-1000Mhz protection with less than ±0.1% of span error –EM Externally-mounted input transformer for current input (available with 0-5AAC input type only)	DIN Aluminum DIN-style housing mounts on 32mm G-type (EN50035) and 35mm Top Hat (EN50022) rails

When ordering, specify: Unit / Input / Output / Power / Options [Housing]

Model number example: ECT / 4-20MA / 4-20MA / 12-42DC –RF [DIN]

Calibration

Prior to shipment, every ECT is subjected to rigorous testing by our team of skilled technicians. Every product Moore Industries manufactures, sells and services is guaranteed to meet the strict quality standards that have become synonymous with our company name.

Before placing your ECT into service, a bench check of basic operation is recommended to ensure that the unit hasn't sustained any damage during transit, and to set zero and span for your application. Every unit should be:

- Checked to verify that the appropriate ECT model has been ordered for the intended application.
- Connected in a calibration setup (described later in this section) and checked for desired output.
- Adjusted for desired zero and span.

Calibration Setup

Table 1 lists the equipment you will need to bench check the ECT. These materials are not supplied by Moore Industries, but should be available in environments suited for calibration and maintenance of electronic instruments.

Figures 2-4 show the calibration setup for the different types of 2-wire ECTs.

Moore Industries recommends that the procedures in this section be carried out at a technician's bench or in a similar, lab-type environment. Do not calibrate the ECT in the field or installed in the application.

Table 1. Gathering the equipment for 2-wire ECT calibration

Device	Specifications
Voltage or Current Calibrator	Adjustable, calibrated to an accuracy of $\pm 0.025\%$ (EDC Model CR 103 or MV 105, or equivalent) Rotek Model 811A (or equivalent) recommended for calibrating ac input units.
Power Supply	Calibrated, 24Vdc, $\pm 10\%$, nominal
Load Resistor	250 ohms ($\pm 0.01\%$) precision
Multimeter	Calibrated to an accuracy of $\pm 0.025\%$, minimum (Keithley Model 197, or Fluke Model 8840 or 8842, or equivalent)
Screwdriver	Standard (Blade-type), head width 3.1mm (0.125 in), maximum

Figure 2. Calibrating the input loop-powered 2-wire ECT [DIN]

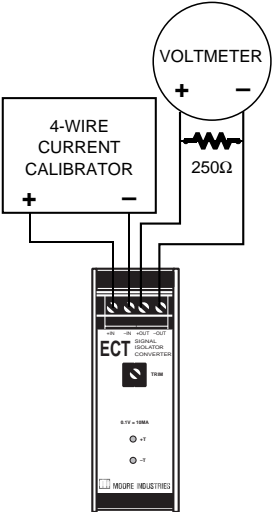

Figure 3. Calibrating the output loop-powered 2-wire ECT [DIN]

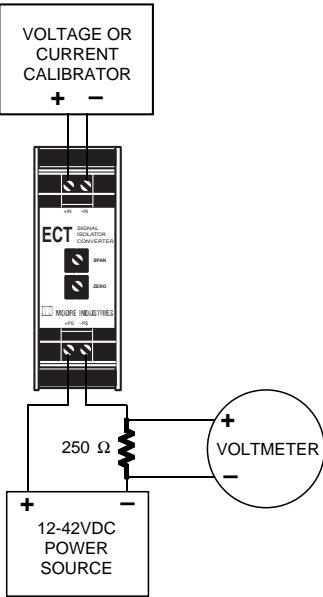
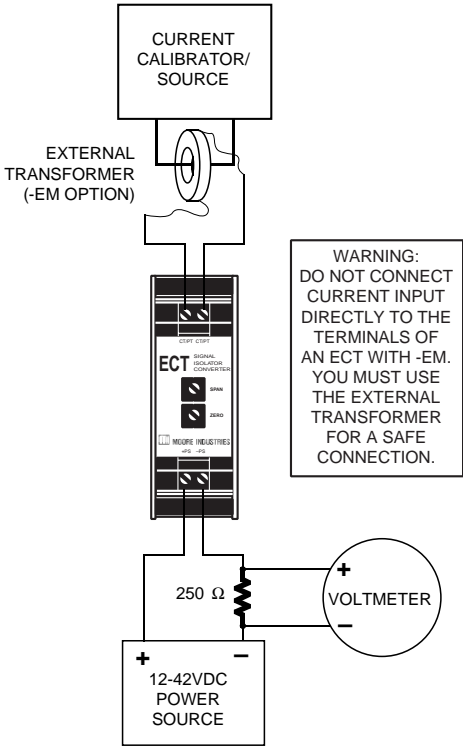

Figure 4. Calibrating the output loop-powered 2-wire ECT [DIN] with the -EM option



ECT

Calibration Procedure

With the unit incorporated into the appropriate setup (as illustrated in Figures 2-4):

1. Apply the appropriate power to the "PS" side of the setup for output-powered units or to the "IN" side of the setup for input-powered ECTs.
2. Set the Voltage or Current Calibrator to 0% of the rated span for the type of ECT being calibrated.

For example, 4mA for a 4-20mA input unit or 1V for a 1-5V input unit.

3. If calibrating an input-powered ECT, skip to step 6.
4. Adjust the ECT Zero potentiometer (pot) until the voltmeter in the setup reads 1V plus/minus the stated accuracy specification.

5. Skip to step 7.
6. If calibrating an input-powered ECT, turn the trim pot fully counter-clockwise, then adjust it clockwise until the voltmeter in the setup reads 1V, plus/minus the stated accuracy specification.
7. Set the calibrator to 100% of the rated span (full scale) for the type of ECT being calibrated.

For example, 20mA for a 4-20mA input unit or 5V for a 1-5V input unit.

8. Adjust the span potentiometer (pot) until the voltmeter reads 5V plus/minus the stated accuracy specification across the precision resistor. If calibrating an input-powered ECT, adjust the trim pot for the application's anticipated load.
9. Repeat steps 2 through 8 until the voltage across the resistor is stable and within rated unit accuracy at both 0% and 100% of span.

Figure 5. Aluminum-housed ECT [DIN] dimensions

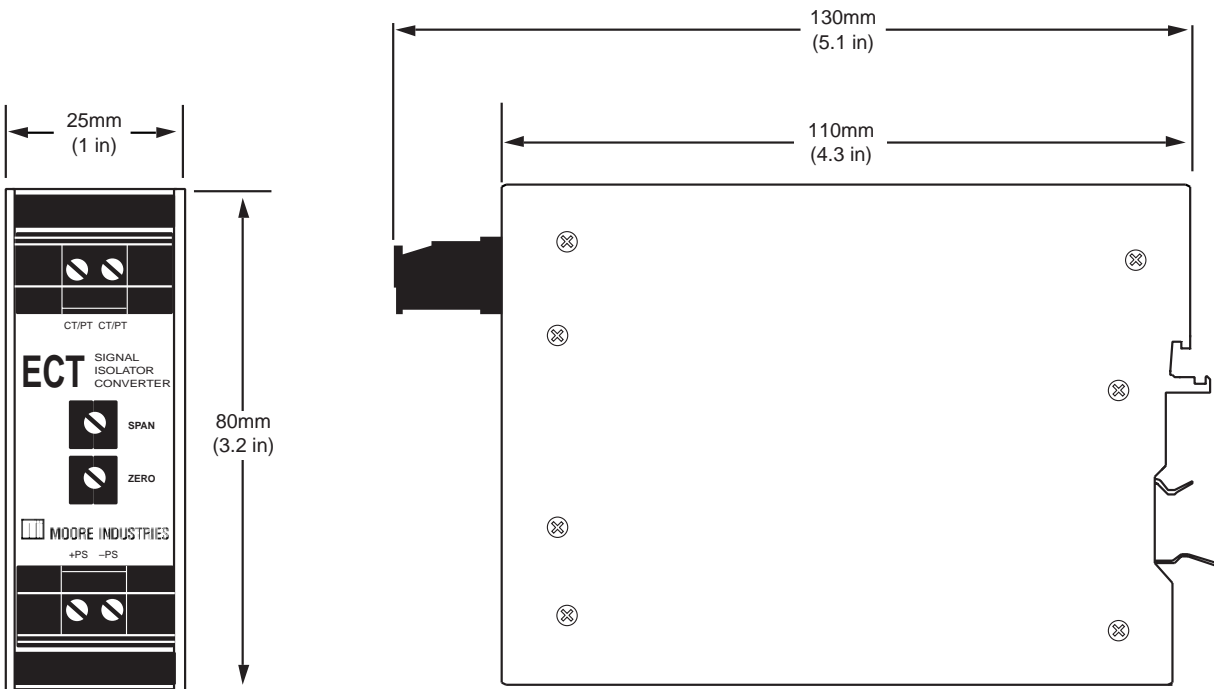

Installation

Figure 5 shows the physical dimensions of the ECT. To install the ECT on a DIN rail, set the appropriate lip on the back of the unit on the top edge of the DIN rail and pivot downward until the unit snaps into place.

Recommended Ground Wiring Practices

The following ground wiring practices must be followed to ensure proper performance of the ECT:

- Any Moore Industries product in a metal case, enclosure or housing should be grounded. Units in DIN housings, for example, should be mounted on a grounded rail.
- All input signals to, and output signals from, Moore Industries' products should be wired using a shielded, twisted pair technique. Shields are to be connected to an earth or safety ground at the unit itself.
- The maximum length of any unshielded input and/or output signal wiring is 2 inches.

CE Conformity

Installation of any Moore Industries' products that carry the CE certification (Commission Electrotechnique) **must** adhere to the guidelines above in order to meet the requirements set forth in applicable EMC (Electromagnetic Compatibility) directives (EN55011, EN 50082-1, EN50082-2, etc.)

Consult the factory for the most current information on products that have been CE certified.

Electrical Connections

When considering the 2-wire ECT units for installation, it may help to group them in terms of their most common applications: standard current or voltage with dc inputs in a loop-powered mode, or standard dc current input in an input loop-powered mode.

Figures 6-8 illustrate the proper hookups for correctly installing an ECT into your process.

Figure 6. Installing the input loop-powered 2-wire ECT [DIN]

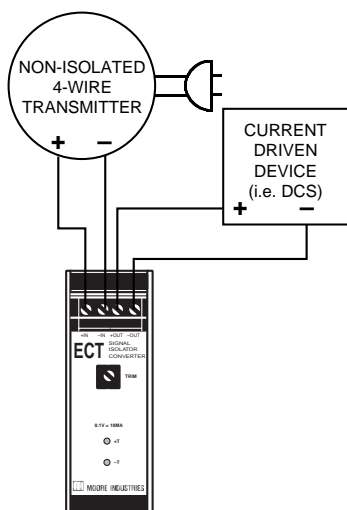

Figure 7. Installing the output loop-powered 2-wire ECT [DIN]

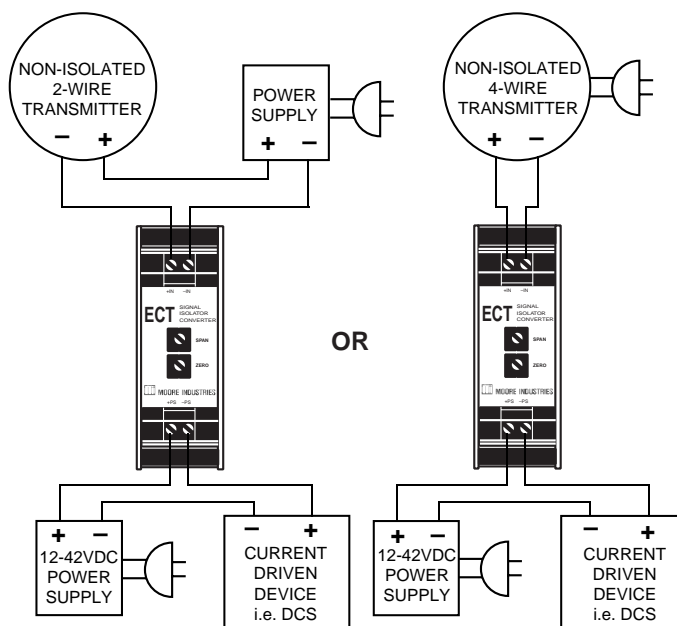
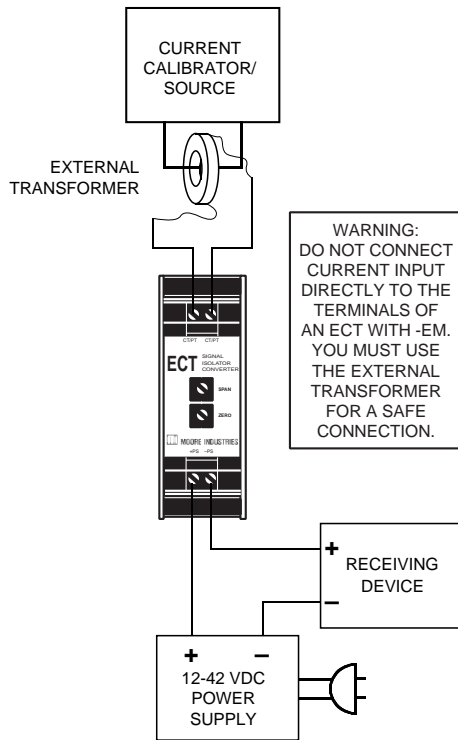

Figure 8. Installing the output loop-powered 2-wire ECT [DIN] with the -EM option



Customer Support

Moore Industries is recognized as the industry leader in delivering top quality to its customers, both in products and services. We perform a battery of stringent quality assurance checks on every unit we ship. If any Moore Industries product fails to perform up to rated specification, call us for help. Our highly skilled staff of trained technicians and engineers pride themselves on their ability to provide timely, accurate, and practical answers to your process instrumentation questions.

If problems involve a particular ECT, there are several pieces of information you can gather **before** you call the factory that will help our staff get your answers more efficiently. When you call, please have:

- The model number of the unit in question
- The serial number of the unit in question
- The job number (if available)
- The purchase order under which the unit was shipped (if available)

Factory contact information is on the back cover.

Supplement

Low Voltage Directive

The following guidelines must be followed in order to comply with EN 61010-1 (Low Voltage Directive). These items affect the AC versions of the following products: DCA, DPS-240, DPS1200, ECA, ECS, ECT [ECD], ECT [DIN], FCA, FDT, IST, PIT-4W, PWT, RBA, SCT, SMP, SPA-CE. If these products are to be used in a non-CE environment, this supplement may be disregarded.

WARNING:

If this unit is used in a manner not specified by Moore Industries, the protection provided by the equipment may be impaired.

Switches and Circuit Breakers

A switch or circuit breaker must be wired in series with the AC power conductors. This switch or circuit breaker must be located within three meters of the unit.

WARNING:

Terminals on this unit may be connected to hazardous voltages. Before making ANY connections to this unit, ALL hazardous voltages must be de-energized.

The circuit breaker or switch will only remove power to the unit, hazardous voltages may still be connected to other terminals on the unit.

Installation Category

All terminals are rated CAT II, except for terminals with the -RF option. These terminals are rated CAT I.

Equipment Ratings

Moore Industries transmitters do not generate hazardous voltages. They measure voltage or current inputs, and generate low voltages and currents (<42Vdc and <50mAdc). Products connected to Moore Industries transmitters should be designed to receive these inputs.

Moore Industries alarms do not generate any hazardous voltages. Alarm contacts are wired in series with power sources and their intended loads.

The correct load should be selected for the power source.

Supply Wiring

All power connections shall be made with 14 or 16 AWG (.083mm or .064mm) wire.

The end of each conductor should be stripped no more than 8mm. The end of the stripped wire should be tinned with solder or inserted into a ferrule and crimped before being placed into a terminal block.

Conductors connected to screw type connections must have a ring or spade lug crimped on the end of the wire.

Protective Earth Conductor

The Protective Earth Conductor shall be of equal or larger size wire than the other two power conductors.

The Protective Earth Conductor shall be the first conductor connected to the unit when the unit is being wired. It shall be the last conductor removed when the unit is being un-wired.

Supplement

Maximum Working Voltage

Table 1-s shows the maximum working voltage for Moore Industries' low voltage products.

Table 1-s. Maximum Working Voltage

Input Type	Maximum Working Voltage
Millivolt, Thermocouple, and RTD	48Vdc
DC Voltage Inputs	48Vdc
AC Voltage Inputs	264Vac
Analog Outputs	48Vdc
Relay Contacts	264Vac
117Vac Power Terminals	129Vac
240Vac Power Terminals	264Vac
Contact Closure Outputs	30Vdc

Accessories

Contact Moore Industries for information on suitable accessories for our products.

Mounting

When mounting the unit or installing it into an application, ensure that the unit can be easily removed for maintenance or repairs.

Cleaning and Maintenance

Maintenance on Moore Industries' products is limited to keeping the unit clean and the wire terminals free of oxidation. This is best accomplished by installing the unit in an area protected from dust, heat, moisture, and corrosive atmospheres. Yearly visual inspections should be performed to ensure that the unit is clean and the electrical connections are in good repair.

Replacement of Consumable Materials

No consumable materials are used in the Moore Industries products covered by EN 61010-1.

Symbols

Table 2-s shows the symbols used on Moore Industries' products, the corresponding IEC/ISO symbol, and its definition.

Table 2-s. Symbols on Moore Industries' Products

IEC/ISO Symbol	Symbol on Moore Industries Product	Definition
	+PS -PS DCC	Direct Current
	AC ACC	Alternating Current
	AC or DC	Direct and Alternating Current
	GND 	Protected Earth Terminal
		Protective Conductor Terminal
		Equipment protected throughout by double insulation or reinforced insulation (equivalent to Class II of IEC 536)
		Caution (See manual for information)
Not Specified	+IN -IN	Positive Input Negative Input
Not Specified	+OUT -OUT	Positive Output Negative Output
Not Specified	NO NC CM	Normally Open Normally Closed Common
Not Specified	UNO UNC	Upper Normally Open Upper Normally Closed
Not Specified	LNO LNC	Lower Normally Open Lower Normally Closed
Not Specified	TX	Transmitter Excitation

RETURN PROCEDURES

To return equipment to Moore Industries for repair, follow these four steps:

1. Call Moore Industries and request a Returned Material Authorization (RMA) number.

Warranty Repair –

If you are unsure if your unit is still under warranty, we can use the unit's serial number to verify the warranty status for you over the phone. Be sure to include the RMA number on all documentation.

Non-Warranty Repair –

If your unit is out of warranty, be prepared to give us a Purchase Order number when you call. In most cases, we will be able to quote you the repair costs at that time. The repair price you are quoted will be a "Not To Exceed" price, which means that the actual repair costs may be less than the quote. Be sure to include the RMA number on all documentation.

2. Provide us with the following documentation:
 - a) A note listing the symptoms that indicate the unit needs repair
 - b) Complete shipping information for return of the equipment after repair
 - c) The name and phone number of the person to contact if questions arise at the factory
3. Use sufficient packing material and carefully pack the equipment in a sturdy shipping container.
4. Ship the equipment to the Moore Industries location nearest you.

The returned equipment will be inspected and tested at the factory. A Moore Industries representative will contact the person designated on your documentation if more information is needed. The repaired equipment, or its replacement, will be returned to you in accordance with the shipping instructions furnished in your documentation.

WARRANTY DISCLAIMER

THE COMPANY MAKES NO EXPRESS, IMPLIED OR STATUTORY WARRANTIES (INCLUDING ANY WARRANTY OF MERCHANTABILITY OR OF FITNESS FOR A PARTICULAR PURPOSE) WITH RESPECT TO ANY GOODS OR SERVICES SOLD BY THE COMPANY. THE COMPANY DISCLAIMS ALL WARRANTIES ARISING FROM ANY COURSE OF DEALING OR TRADE USAGE, AND ANY BUYER OF GOODS OR SERVICES FROM THE COMPANY ACKNOWLEDGES THAT THERE ARE NO WARRANTIES IMPLIED BY CUSTOM OR USAGE IN THE TRADE OF THE BUYER AND OF THE COMPANY, AND THAT ANY PRIOR DEALINGS OF THE BUYER WITH THE COMPANY DO NOT IMPLY THAT THE COMPANY WARRANTS THE GOODS OR SERVICES IN ANY WAY.

ANY BUYER OF GOODS OR SERVICES FROM THE COMPANY AGREES WITH THE COMPANY THAT THE SOLE AND EXCLUSIVE REMEDIES FOR BREACH OF ANY WARRANTY CONCERNING THE GOODS OR SERVICES SHALL BE FOR THE COMPANY, AT ITS OPTION, TO REPAIR OR REPLACE THE GOODS OR SERVICES OR REFUND THE PURCHASE PRICE. THE COMPANY SHALL IN NO EVENT BE LIABLE FOR ANY CONSEQUENTIAL OR INCIDENTAL DAMAGES EVEN IF THE COMPANY FAILS IN ANY ATTEMPT TO REMEDY DEFECTS IN THE GOODS OR SERVICES, BUT IN SUCH CASE THE BUYER SHALL BE ENTITLED TO NO MORE THAN A REFUND OF ALL MONIES PAID TO THE COMPANY BY THE BUYER FOR PURCHASE OF THE GOODS OR SERVICES.

ANY CAUSE OF ACTION FOR BREACH OF ANY WARRANTY BY THE COMPANY SHALL BE BARRED UNLESS THE COMPANY RECEIVES FROM THE BUYER A WRITTEN NOTICE OF THE ALLEGED DEFECT OR BREACH WITHIN TEN DAYS FROM THE EARLIEST DATE ON WHICH THE BUYER COULD REASONABLY HAVE DISCOVERED THE ALLEGED DEFECT OR BREACH, AND NO ACTION FOR THE BREACH OF ANY WARRANTY SHALL BE COMMENCED BY THE BUYER ANY LATER THAN TWELVE MONTHS FROM THE EARLIEST DATE ON WHICH THE BUYER COULD REASONABLY HAVE DISCOVERED THE ALLEGED DEFECT OR BREACH.

RETURN POLICY

For a period of thirty-six (36) months from the date of shipment, and under normal conditions of use and service, Moore Industries ("The Company") will at its option replace, repair or refund the purchase price for any of its manufactured products found, upon return to the Company (transportation charges prepaid and otherwise in accordance with the return procedures established by The Company), to be defective in material or workmanship. This policy extends to the original Buyer only and not to Buyer's customers or the users of Buyer's products, unless Buyer is an engineering contractor in which case the policy shall extend to Buyer's immediate customer only. This policy shall not apply if the product has been subject to alteration, misuse, accident, neglect or improper application, installation, or operation. THE COMPANY SHALL IN NO EVENT BE LIABLE FOR ANY INCIDENTAL OR CONSEQUENTIAL DAMAGES.



The Interface Solution Experts • www.miinet.com

United States • info@miinet.com
Tel: (818) 894-7111 • FAX: (818) 891-2816
Australia • sales@mooreind.com.au
Tel: (02) 8536-7200 • FAX: (02) 9525-7296

Belgium • info@mooreind.be
Tel: 03/448.10.18 • FAX: 03/440.17.97
The Netherlands • sales@mooreind.nl
Tel: (0)344-617971 • FAX: (0)344-615920

China • sales@mooreind.sh.cn
Tel: 86-21-62481120 • FAX: 86-21-62490635
United Kingdom • sales@mooreind.com
Tel: 01293 514488 • FAX: 01293 536852