

**ECT [DIN]**  
4-Wire Isolator, Converter, Repeater,  
and Splitter in an Aluminum Housing



# Table of Contents

<b>Introduction</b> .....	<b>1</b>
<b>Specifications</b> .....	<b>1</b>
<b>Ordering Information</b> .....	<b>2</b>
<b>Calibration</b> .....	<b>4</b>
Calibration Setup .....	4
Calibration Procedure .....	4
Calibration Diagrams .....	5-7
<b>Installation</b> .....	<b>8</b>
Recommended Ground Wiring Practices .....	8
Electrical Connections .....	8
Installation Diagrams .....	8-10
<b>Customer Support</b> .....	<b>10</b>

## Introduction

This is the users' manual for Moore Industries' line of 4-wire, Economy Signal Isolator/Converters, the ECT [DIN]. Available in configurations that accept a variety of inputs, the principal function of the ECT family of products is to provide low cost isolation between instruments at either end of a process loop.

ECTs furnish up to 1500Vrms isolation between transmitting and receiving devices.

The ECT can also function as a low-cost signal converter or splitter. Configurations accommodate a single input and your choice of one or two accurate outputs. Inputs and outputs are available in a variety of industry standard ranges. Refer to the Ordering Information table for more information.

The ECT is a highly cost-effective means of protecting process signals from distortions associated with ground loops, motor noise, and other common types of electrical interference.

## Specifications

<p><b>Performance</b> <b>Accuracy:</b> <math>\pm 0.1\%</math> of span <b>Stability:</b> <math>\pm 0.2\%</math> of reading per year <b>Isolation:</b> Without -RF option: 1500Vrms between input and output and power; With -RF option: 500Vrms between input and output, 1500Vrms power terminals <b>Output Response Time:</b> DC Input: 100msec, maximum to 99% of output; AC Input: 400msec, maximum, from 0-99% of output <b>DC Input Resistance:</b> 50<math>\Omega</math> <b>Ripple:</b> 10mV peak-to-peak maximum measured across 250 ohm resistor <b>Load Effect:</b> Current Output: 1000<math>\Omega</math> for single channel unit, 600<math>\Omega</math> for splitter; Voltage Output: 5K<math>\Omega</math> for single channel unit, 10K<math>\Omega</math> for dual channel unit (splitter)</p>	<p><b>Performance (continued)</b> <b>Power Supply Effect:</b> Exceeds 90db for current input unit <b>Maximum Input Overrange:</b> 250% of full scale for current inputs; 150% of full scale for DC voltage inputs; <b>Burden:</b> 1V maximum with 4-20mA input; 0.01V maximum with 0-5A input; <b>Output Current Limiting:</b> 25mA, typical; 30mA, max.</p> <p><b>Ambient Conditions</b> <b>Operating Range:</b> -40°C to +85°C (-40°F to +185°F) <b>Storage Range:</b> -40°C to +85°C (-40°F to +185°F) <b>Ambient Temperature Effect:</b> <math>\pm 0.007\%</math> of span/°C, typical; <math>\pm 0.015\%</math> of span/°C, max. <b>Relative Humidity:</b> 0-95% non-condensing</p>	<p><b>Ambient Conditions (Continued)</b> <b>RFI/EMI Protection:</b> Without -RF option: Less than <math>\pm 0.1\%</math> of span error when tested at 10V/m@20-1000MHZ With -RF option: Less than <math>\pm 0.1\%</math> of span error when tested at 30V/m@20-1000MHZ <b>Common Mode Rejection:</b> Exceeds 95 dB @ 60Hz with a limit of 1500Vrms</p> <p><b>Adjustments</b> Front panel potentiometer <b>Span:</b> <math>\pm 10\%</math> <b>Zero:</b> <math>\pm 5\%</math> (non-interactive when span is set first)</p> <p><b>Weight</b> <b>Single I/O Channel:</b> 384g (13.7oz) max. <b>Dual I/O Channel:</b> 431g (15.4 oz) max.</p>
---	---	--

## Ordering Information

Unit	Input	Output	Power	Option	Housing
ECT 4-Wire (Line/ Mains) Economy Isolator, Converter, Repeater, and Splitter	<b>4-20MA</b> into 50Ω <b>1-5V</b> into 1MΩ <b>0-10V</b> into 1MΩ <b>0-150AC</b> into 100KΩ <b>0-5AAC</b> into 0.002Ω	SINGLE OUTPUT CHANNEL: <b>4-20MA</b> into 1000Ω <b>0-10V</b> into 5KΩ minimum  DUAL OUTPUT CHANNELS: <b>2X4-20MA</b> into 600Ω (–TX 24V transmitter excitation for powering a 2-wire transmitter is standard on models with dual output channels)	<b>24DC</b> , ±10% <b>117AC</b> , 50/60Hz, ±10% <b>230AC</b> , 50/60Hz, ±10% (3 watts max. for single channel models; 5 watts maximum for dual channel models)	– <b>EM</b> Externally-mounted input transformer for current input (available with 0-5AAC input only) – <b>TX</b> 24V transmitter excitation for powering a 2-wire transmitter (Available on 4-20MA input/output models only; standard on 2X4-20MA models) – <b>RF</b> Enhanced RFI/EMI protection provides 30V/ m@20-1000MHZ protection with less than ±0.1% of span error (–EM option required for AC current input)	<b>DIN</b> Aluminum, DIN-style housing mounts on 32mm G-type (EN50035) and 35mm Top Hat (EN50022) rails

**When ordering, specify:** Unit / Input / Output / Power / Options [Housing]

**Model number example:** ECT / 0-5AAC / 4-20MA / 117AC / -RF [DIN]

## Options

The following paragraphs describe the options available with the ECT family of transmitters:

- **EM – Externally Mounted Transformer**, for use with the 0-5AAC input configuration, this option consists of a toroidal transformer that physically separates high-level current input from the receiving device in a process loop. This provides the added convenience of allowing the servicing of receivers without having to interrupt process signals.
- **TX – Transmitter Excitation**, available for use with the 4-20mA input configuration, TX-equipped ECTs provide power for a 2-wire transmitter in the process loop, eliminating the need to provide separate power supplies for the non-isolated transmitters.
- **RF – RFI/EMI Protection**, available for use with our new aluminum housings, this option provides you with outstanding protection against RFI and EMI interference. Units with the –RF option are provided with 30V/m@20-1000MHZ protection with less than ±0.1% of span error. (requires –EM option for ac current input)

Figure 1. Dimensions of the aluminum-housed ECT and ECT Splitter [DIN]

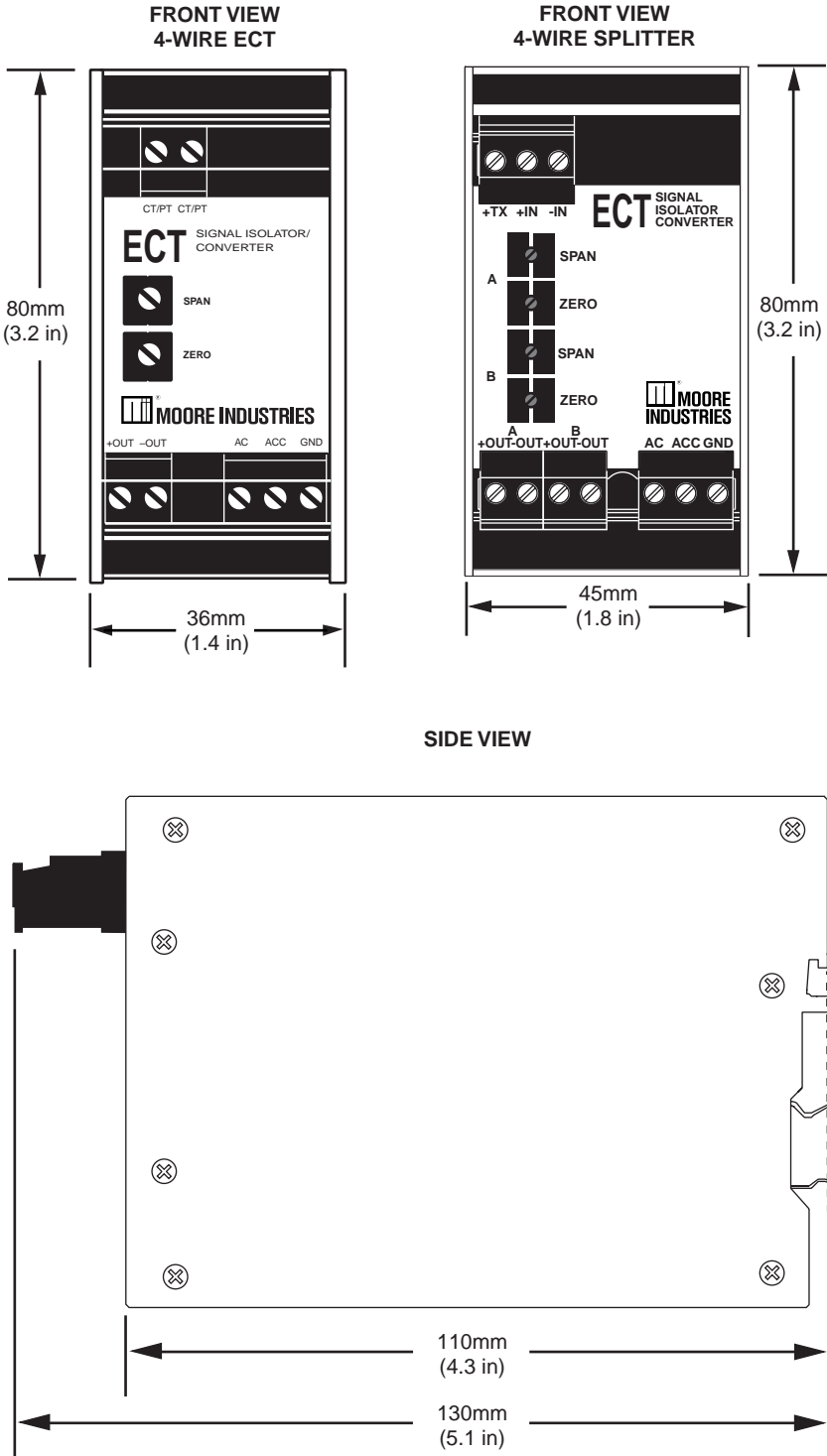

## Calibration

Prior to shipment, every ECT is subjected to rigorous testing by our team of skilled technicians. Every product Moore Industries manufactures, sells and services is guaranteed to meet the strict quality standards that have become synonymous with our company name.

Before placing your ECT into service, a bench check of basic operation is recommended to ensure that the unit hasn't sustained any damage during transit, and to set zero and span points for your application.

### Every unit should be:

- Checked to verify that the appropriate ECT model has been ordered for the intended application.
- Connected in a calibration setup (described later in this section) and checked for desired output.
- Adjusted for desired zero and span.

**Table 1.** Gathering the equipment for 4-wire ECT calibration

Device	Specifications
Voltage/Current Calibrator	Adjustable, calibrated to an accuracy of $\pm 0.025\%$ (EDC Model CR 103 or MV 105, or equivalent)  Rotek Model 811A (or equivalent) recommended for calibrating ac input units.
Power Supply	Calibrated, 24Vdc, $\pm 0.01\%$ , nominal
Load Resistor	250 ohms ( $\pm 10\%$ ) precision
Multimeter	Calibrated to an accuracy of $\pm 0.025\%$ , minimum (Keithley Model 197, or Fluke Model 8840 or 8842, or equivalent)
Screwdriver	Standard (Blade-type), head width 3.1mm (0.125 in), maximum

## Calibration Setup

Table 1 lists the equipment you will need to bench check the ECT. These materials are not supplied by Moore Industries, but should be available in those environments suited for calibration and maintenance of electronic instruments.

Figures 2-4 show the calibration setups for each type of ECT. Moore Industries recommends that the procedures in this section be carried out at a technician's bench or in a similar, lab-type environment. Do not calibrate the ECT in the field or installed in the application.

## Calibration Procedure

With the unit incorporated into the setup described in the appropriate Figure (2-4):

1. Apply the appropriate power to the ECT.
2. Set the Voltage or Current Calibrator to 100% span (full scale input) for the type of ECT being calibrated. For example, 20mA for a 4-20mA input unit or 5V for a 1-5V input unit.
3. Adjust the Span potentiometer (pot) until the multimeter reads 20mA, plus/minus the stated accuracy specification. If measuring the voltage drop across the precision resistor, adjust the pot until output is 5V, plus/minus the stated accuracy specification.
4. Set the Calibrator to 0% of the rated span for the type of ECT being calibrated. For example, 4mA for a 4-20mA input unit or 1V for a 1-5V input unit.
5. Adjust the Zero pot until the multimeter reads 4mA, plus/minus the stated accuracy specification. If measuring the voltage drop across the precision resistor, adjust the pot until output is 1V, plus/minus the stated accuracy specification.
6. Repeat steps 2 through 5 for each channel until the ECT output or the voltage across the resistor is stable at both 0 and 100% of rated input span.

Figure 2. Calibrating the 4-wire aluminum-housed ECT

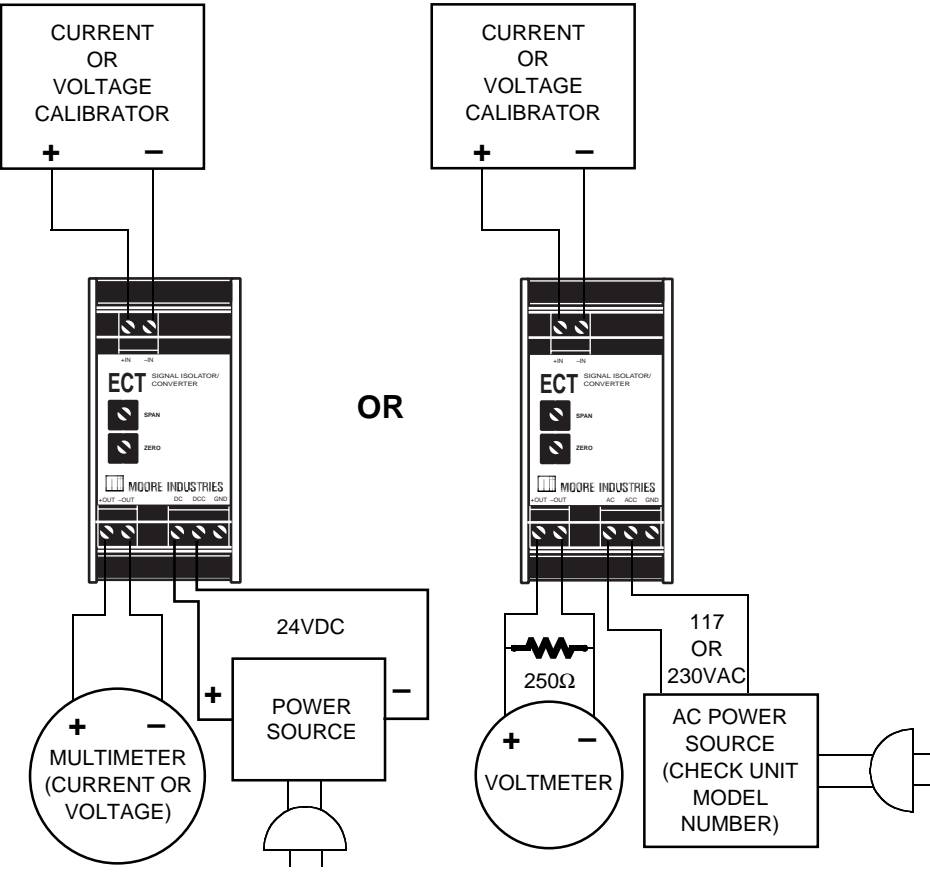

IF DESIRED, FOR CURRENT  
OUTPUTS, MEASURE VOLTAGE  
DROP ACROSS A 250Ω PRECISION  
RESISTOR. 1-5V = 4-20MA

# ECT

Figure 3. Calibrating the 4-wire aluminum-housed ECT equipped with the -EM option

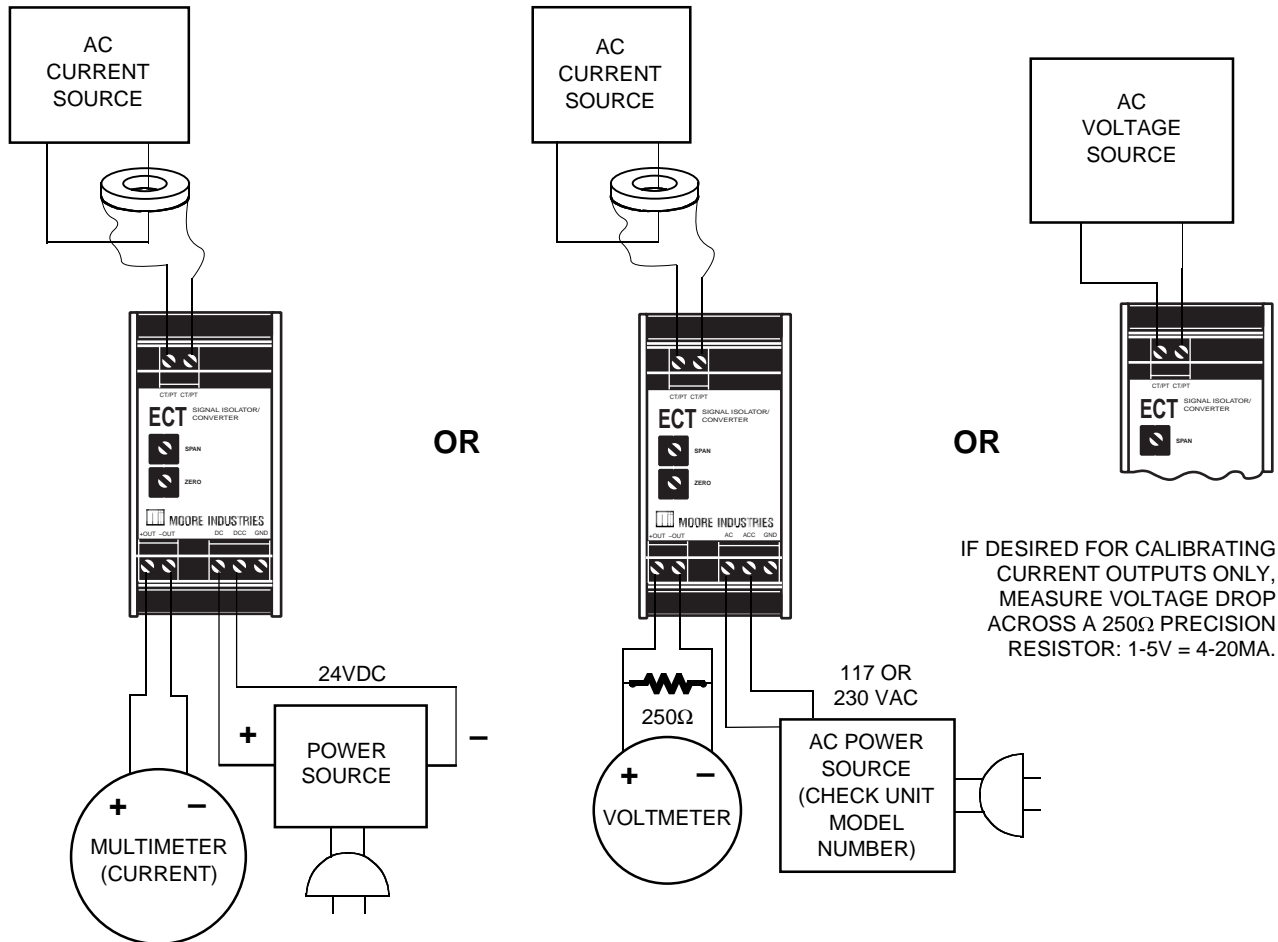
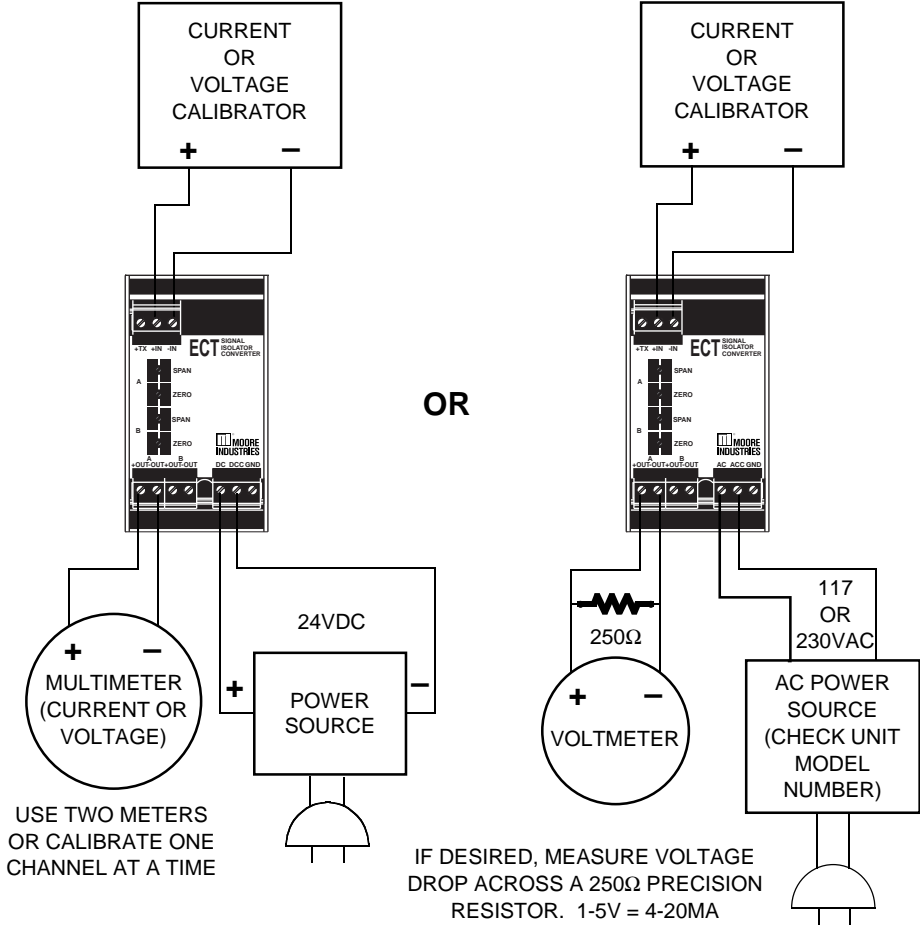

Figure 4. Calibrating the 4-wire aluminum-housed ECT Dual I/O Channel Splitter



# ECT

## Installation

Figure 1 on page 3 shows the physical dimensions of the 4-wire ECT family. To install an ECT, set the appropriate lip on the top edge of the DIN rail and pivot downward until the unit snaps into place.

## Recommended Ground Wiring Practices

The following ground wiring practices must be followed to ensure proper performance of the ECT:

- Any Moore Industries products in a metal case, housing or enclosure should be grounded. Units in DIN housings, for example, should be mounted on a grounded rail.
- All input signals to, and output signals from, Moore Industries' products should be wired using a shielded, twisted pair technique. Shields are to be connected to an earth or safety ground at the unit itself.
- The maximum length of any unshielded input and/or output signal wiring is 2 inches.

## CE Conformity

Installation of any Moore Industries products that carry the CE certification (Commission Electrotechnique) **must** adhere to the guidelines above in order to meet the requirements set forth in applicable EMC (Electromagnetic Compatibility) directives (EN 55011, EN 50082-1, EN 50082-2, etc.).

Consult the factory for the most current information on products that have been CE certified.

## Electrical Connections

Figures 5-8 show typical types of 4-wire ECT installations. Simply hookup the ECT in the directed manner, making sure to notice any pertinent notes.

Figure 5. Installing the 4-wire aluminum-housed ECT

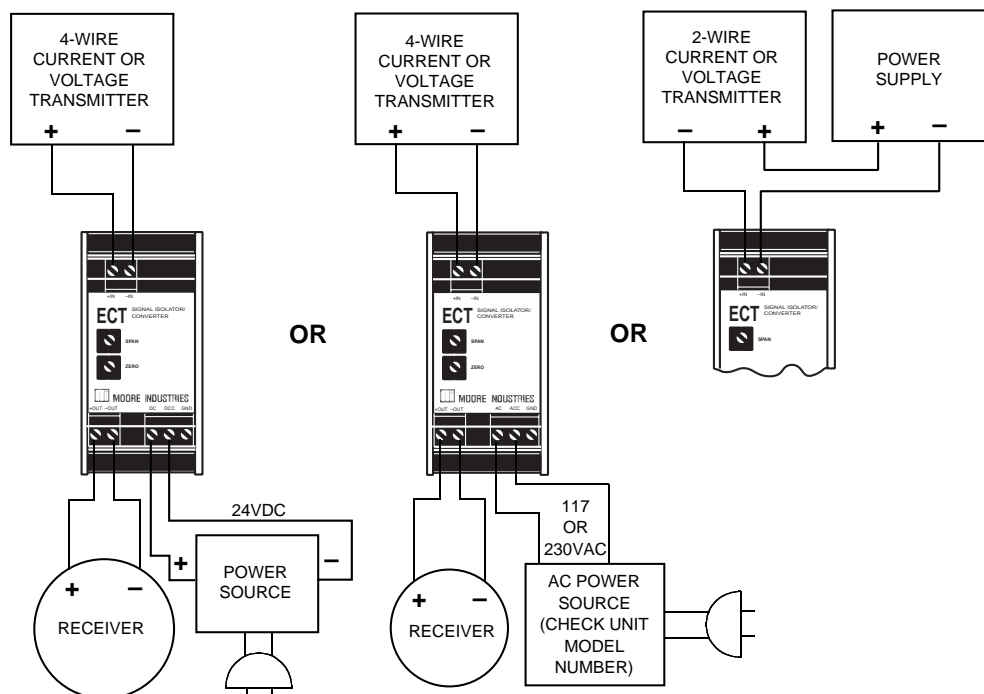

Figure 6. Installing the 4-wire aluminum-housed ECT with -EM option

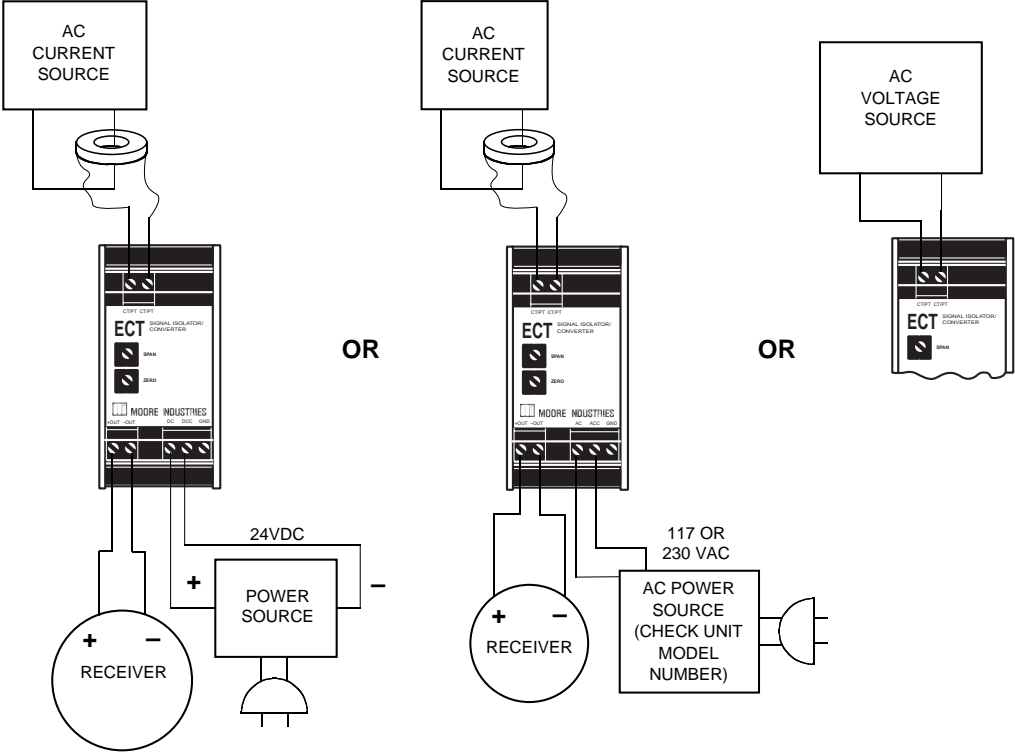
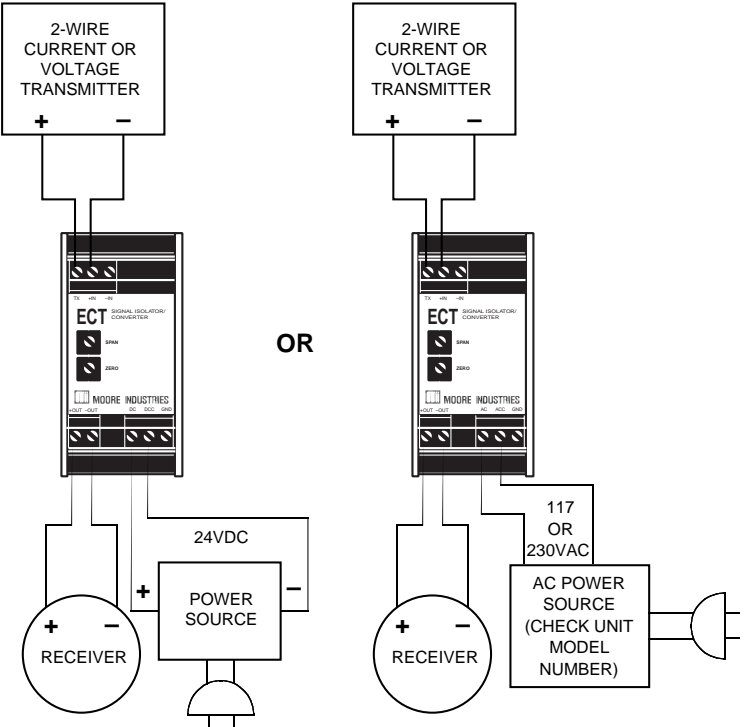
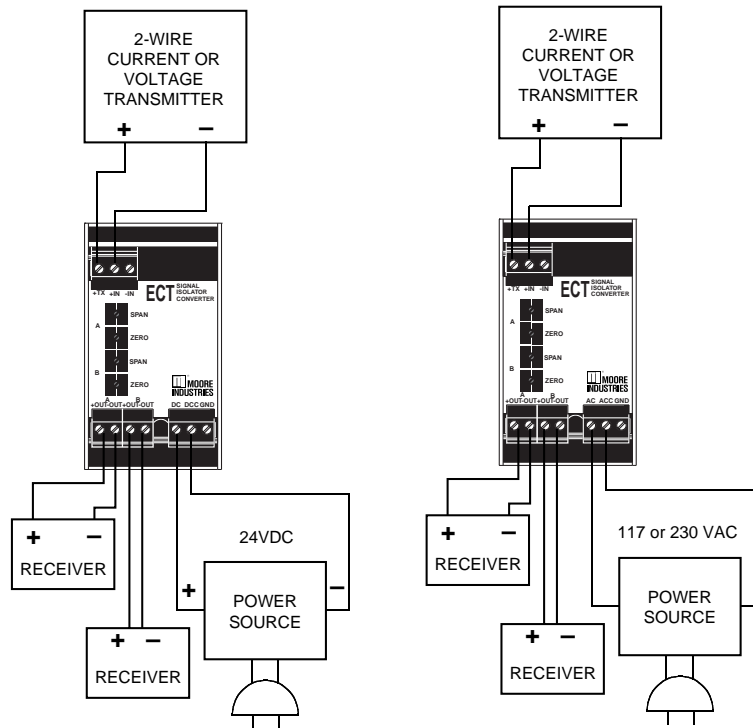

Figure 7. Installing the 4-wire aluminum-housed ECT with -TX option



# ECT

Figure 8. Installing the 4-wire aluminum-housed ECT Dual I/O Channel Splitter



## Customer Support

Moore Industries is recognized as the industry leader in delivering top quality to its customers, both in products and services. We perform a battery of stringent quality assurance checks on every unit we ship. If any Moore Industries product fails to perform up to rated specification, call us for help. Our highly skilled staff of trained technicians and engineers pride themselves on their ability to provide timely, accurate, and practical answers to your process instrumentation questions.

If problems involve a particular ECT, there are several pieces of information you can gather **before** you call the factory that will help our staff to get you answers more efficiently. When you call, please have:

- The model number of the unit in question
- The serial number of the unit in question
- The job number (if available)
- The purchase order under which the unit was shipped (if available)

Factory phone numbers are on the back cover.

# Supplement

---

## Low Voltage Directive

The following guidelines must be followed in order to comply with EN 61010-1 (Low Voltage Directive). These items affect the AC versions of the following products: DCA, DPS-240, DPS1200, ECA, ECS, ECT [ECD], ECT [DIN], FCA, FDT, IST, PIT-4W, PWT, RBA, SCT, SMP, SPA-CE. If these products are to be used in a non-CE environment, this supplement may be disregarded.

**WARNING:**

*If this unit is used in a manner not specified by Moore Industries, the protection provided by the equipment may be impaired.*

## Switches and Circuit Breakers

A switch or circuit breaker must be wired in series with the AC power conductors. This switch or circuit breaker must be located within three meters of the unit.

**WARNING:**

*Terminals on this unit may be connected to hazardous voltages. Before making ANY connections to this unit, ALL hazardous voltages must be de-energized.*

The circuit breaker or switch will only remove power to the unit, hazardous voltages may still be connected to other terminals on the unit.

## Installation Category

All terminals are rated CAT II, except for terminals with the -RF option. These terminals are rated CAT I.

## Equipment Ratings

Moore Industries transmitters do not generate hazardous voltages. They measure voltage or current inputs, and generate low voltages and currents (<42Vdc and <50mAdc). Products connected to Moore Industries transmitters should be designed to receive these inputs.

Moore Industries alarms do not generate any hazardous voltages. Alarm contacts are wired in series with power sources and their intended loads.

The correct load should be selected for the power source.

## Supply Wiring

All power connections shall be made with 14 or 16 AWG (.083mm or .064mm) wire.

The end of each conductor should be stripped no more than 8mm. The end of the stripped wire should be tinned with solder or inserted into a ferrule and crimped before being placed into a terminal block.

Conductors connected to screw type connections must have a ring or spade lug crimped on the end of the wire.

## Protective Earth Conductor

The Protective Earth Conductor shall be of equal or larger size wire than the other two power conductors.

The Protective Earth Conductor shall be the first conductor connected to the unit when the unit is being wired. It shall be the last conductor removed when the unit is being un-wired.

# Supplement

## Maximum Working Voltage

Table 1-s shows the maximum working voltage for Moore Industries' low voltage products.

**Table 1-s.** Maximum Working Voltage

Input Type	Maximum Working Voltage
Millivolt, Thermocouple, and RTD	48Vdc
DC Voltage Inputs	48Vdc
AC Voltage Inputs	264Vac
Analog Outputs	48Vdc
Relay Contacts	264Vac
117Vac Power Terminals	129Vac
240Vac Power Terminals	264Vac
Contact Closure Outputs	30Vdc

## Accessories

Contact Moore Industries for information on suitable accessories for our products.

## Mounting

When mounting the unit or installing it into an application, ensure that the unit can be easily removed for maintenance or repairs.

## Cleaning and Maintenance

Maintenance on Moore Industries' products is limited to keeping the unit clean and the wire terminals free of oxidation. This is best accomplished by installing the unit in an area protected from dust, heat, moisture, and corrosive atmospheres. Yearly visual inspections should be performed to ensure that the unit is clean and the electrical connections are in good repair.

## Replacement of Consumable Materials

No consumable materials are used in the Moore Industries products covered by EN 61010-1.

## Symbols

Table 2-s shows the symbols used on Moore Industries' products, the corresponding IEC/ISO symbol, and its definition.

**Table 2-s.** Symbols on Moore Industries' Products

IEC/ISO Symbol	Symbol on Moore Industries Product	Definition
	+PS -PS DCC	Direct Current
	AC ACC	Alternating Current
	AC or DC	Direct and Alternating Current
	GND 	Protected Earth Terminal
		Protective Conductor Terminal
		Equipment protected throughout by double insulation or reinforced insulation (equivalent to Class II of IEC 536)
		Caution (See manual for information)
Not Specified	+IN -IN	Positive Input Negative Input
Not Specified	+OUT -OUT	Positive Output Negative Output
Not Specified	NO NC CM	Normally Open Normally Closed Common
Not Specified	UNO UNC	Upper Normally Open Upper Normally Closed
Not Specified	LNO LNC	Lower Normally Open Lower Normally Closed
Not Specified	TX	Transmitter Excitation



# RETURN PROCEDURES

To return equipment to Moore Industries for repair, perform the following:

1. Notify the local Moore Industries' Sales Representative or a factory Customer Service Representative that you are returning equipment for repair. Furnish the Moore Industries' representative with the model and serial number(s) of the equipment to be returned.
2. In a cover letter or note, describe completely the following:
  - a. the symptoms that indicate the equipment needs repair
  - b. the environment in which the equipment has been operating (vibration, temperature, etc.)
  - c. approximate number of operating hours or approximate installation date (if known)
  - d. complete shipping information for return of the equipment after repair
  - e. the name and phone number of the person to contact if questions arise at the factory
3. Enclose the cover letter, packing list, copies of rejection or discrepancy reports (if available), and purchase order or purchase order number with the equipment.
4. Use sufficient packing material and carefully pack the equipment in a sturdy shipping container.
5. Ship the equipment to the Customer Service Department nearest you.

The returned equipment will be inspected and tested at the factory. A Moore Industries' representative will contact the person designated in the cover letter if more information is needed.

In case of repair pursuant to Moore Industries' return policy, the defective equipment will be either replaced, or the purchase price refunded, at Moore Industries option. The equipment or its replacement will be returned to you in accordance with the shipping instructions furnished in your cover letter.

In other cases, the Moore Industries' representative will advise you of the repair cost and estimated return date, if requested in your letter. Repair in such instances must be authorized by a purchase order number before the equipment can be repaired and returned.

## WARRANTY DISCLAIMER

THE COMPANY MAKES NO EXPRESS, IMPLIED OR STATUTORY WARRANTIES (INCLUDING ANY WARRANTY OF MERCHANTABILITY OR OF FITNESS FOR A PARTICULAR PURPOSE) WITH RESPECT TO ANY GOODS OR SERVICES SOLD BY THE COMPANY. THE COMPANY DISCLAIMS ALL WARRANTIES ARISING FROM ANY COURSE OF DEALING OR TRADE USAGE, AND ANY BUYER OF GOODS OR SERVICES FROM THE COMPANY ACKNOWLEDGES THAT THERE ARE NO WARRANTIES IMPLIED BY CUSTOM OR USAGE IN THE TRADE OF THE BUYER AND OF THE COMPANY, AND THAT ANY PRIOR DEALINGS OF THE BUYER WITH THE COMPANY DO NOT IMPLY THAT THE COMPANY WARRANTS THE GOODS OR SERVICES IN ANY WAY.

ANY BUYER OF GOODS OR SERVICES FROM THE COMPANY AGREES WITH THE COMPANY THAT THE SOLE AND EXCLUSIVE REMEDIES FOR BREACH OF ANY WARRANTY CONCERNING THE GOODS OR SERVICES SHALL BE FOR THE COMPANY, AT ITS OPTION, TO REPAIR OR REPLACE THE GOODS OR SERVICES OR REFUND THE PURCHASE PRICE. THE COMPANY SHALL IN NO EVENT BE LIABLE FOR ANY CONSEQUENTIAL OR INCIDENTAL DAMAGES EVEN IF THE COMPANY FAILS IN ANY ATTEMPT TO REMEDY DEFECTS IN THE GOODS OR SERVICES, BUT IN SUCH CASE THE BUYER SHALL BE ENTITLED TO NO MORE THAN A REFUND OF ALL MONIES PAID TO THE COMPANY BY THE BUYER FOR PURCHASE OF THE GOODS OR SERVICES.

ANY CAUSE OF ACTION FOR BREACH OF ANY WARRANTY BY THE COMPANY SHALL BE BARRED UNLESS THE COMPANY RECEIVES FROM THE BUYER A WRITTEN NOTICE OF THE ALLEGED DEFECT OR BREACH WITHIN TEN DAYS FROM THE EARLIEST DATE ON WHICH THE BUYER COULD REASONABLY HAVE DISCOVERED THE ALLEGED DEFECT OR BREACH, AND NO ACTION FOR THE BREACH OF ANY WARRANTY SHALL BE COMMENCED BY THE BUYER NO LATER THAN TWELVE MONTHS FROM THE EARLIEST DATE ON WHICH THE BUYER COULD REASONABLY HAVE DISCOVERED THE ALLEGED DEFECT OR BREACH.

## RETURN POLICY

For a period of thirty-six (36) months from the date of shipment, and under normal conditions of use and service, Moore Industries ("The Company") will at its option replace, repair or refund the purchase price for any of its manufactured products found, upon return to the Company (transportation charges prepaid and otherwise in accordance with the return procedures established by The Company), to be defective in material or workmanship. This policy extends to the original Buyer only and not to Buyer's customers or the users of Buyer's products, unless Buyer is an engineering contractor in which case the policy shall extend to Buyer's immediate customer only. This policy shall not apply if the product has been subject to alteration, misuse, accident, neglect or improper application, installation, or operation. THE COMPANY SHALL IN NO EVENT BE LIABLE FOR ANY INCIDENTAL OR CONSEQUENTIAL DAMAGES.



United States • [info@miinet.com](mailto:info@miinet.com)  
Tel: (818) 894-7111 • FAX: (818) 891-2816  
Australia • [sales@mooreind.com.au](mailto:sales@mooreind.com.au)  
Tel: (02) 8536-7200 • FAX: (02) 9525-7296

Belgium • [info@mooreind.be](mailto:info@mooreind.be)  
Tel: 03/448.10.18 • FAX: 03/440.17.97  
The Netherlands • [sales@mooreind.nl](mailto:sales@mooreind.nl)  
Tel: (0)344-617971 • FAX: (0)344-615920

China • [sales@mooreind.sh.cn](mailto:sales@mooreind.sh.cn)  
Tel: 86-21-62481120 • FAX: 86-21-62490635  
United Kingdom • [sales@mooreind.com](mailto:sales@mooreind.com)  
Tel: 01293 514488 • FAX: 01293 536852

The Interface Solution Experts • [www.miinet.com](http://www.miinet.com)