

SIY PC-Programmable
Signal Isolator/Converter

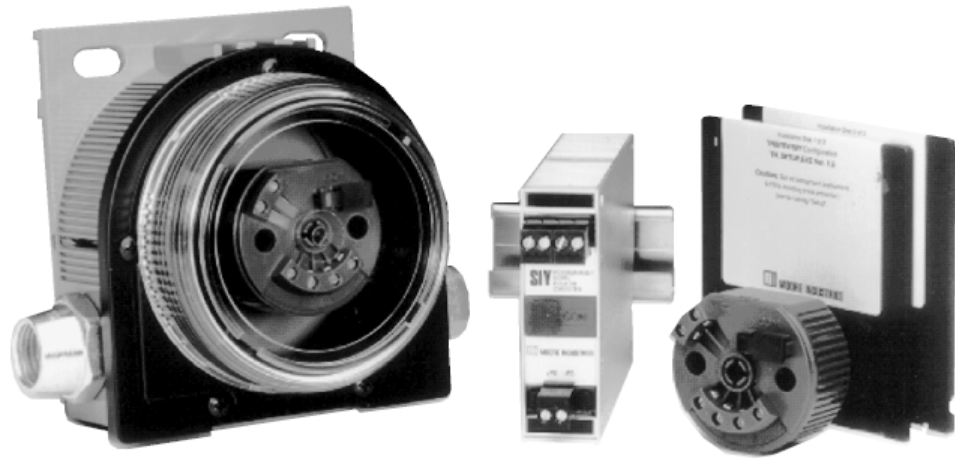



Table of Contents

Introduction	1
The SIY	1
Specifications	2
Ordering Information	3
SIY Model Numbers—Ordering	4
Factory Calibration	4
Accessories	4
Configuration & Bench Check	4
What You Will Need	5
Installing the SIY Software	5
Bench Check Setup	6
Using TR_SETUP.EXE	7
Saving the SIY Configuration File to Disk	8
Using a Configuration File Already on Disk	9
Loading a Configuration File from an SIY	10
Setting Output Damping	10
Trimming SIY Output	10
Trimming SIY Input	11
Method 1	11
Method 2	11
Verifying Input Trim	15
Creating a Custom Linearization Table	16
Scaling the SIY Output	18
Getting Help	19
Installation	19
Mounting and Connections	19
Mounting the HPP-housed SIY	19
Mounting the DIN-housed SIY	19
Electrical Connections for the HPP-housed SIY	19
Electrical Connections for the DIN-housed SIY	19
Ground Wiring Recommendations	19
CE Conformity	21
Operation	21
Maintenance	21
Troubleshooting	21
Customer Support	22

Introduction

This is the users' manual for Moore Industries' SIY PC-Programmable Signal Isolator/Converter. It contains all of the information that is needed to configure, install, operate, maintain, and troubleshoot the SIY. If you require additional assistance, call one of our STAR Centers (for Service, Technical Assistance, and Repair) to talk with a technician or engineer.

WARNING – Hazardous procedure or condition that could injure the operator.

Caution – Hazardous procedure or condition that could damage or destroy the unit.

Note – Information that is helpful for a procedure, condition, or operation of the unit.

The SIY

The SIY is a versatile, 2-wire (loop-powered), PC-Programmable Signal Isolator/Converter that accepts current or voltage input and provides an isolated, proportional 4-20mA output. See Figure 1 for a list of accommodated input types.

Typical uses for the SIY include:

- **Isolating Signals** to stop erratic process measurements caused by ground loops
- **Converting Signals** so field instruments can interface directly with indicators, recorders, DCS's, PLC's, and PC-based SCADA systems
- **Diverting Signals** so the output from one transmitter can be sent to two separate locations
- **Protecting Equipment and Signals** by eliminating common electrical paths
- **Boosting Signals** to enable more instruments to be added to an overburdened loop
- **Solving the "Bucking Power Supplies"** problem that occurs when a 4-wire transmitter and a DCS both try to power the same process loop

Figure 1. Compact, yet powerful, the SIY transmitter features programmable inputs and a trimmable output to boost accuracy.

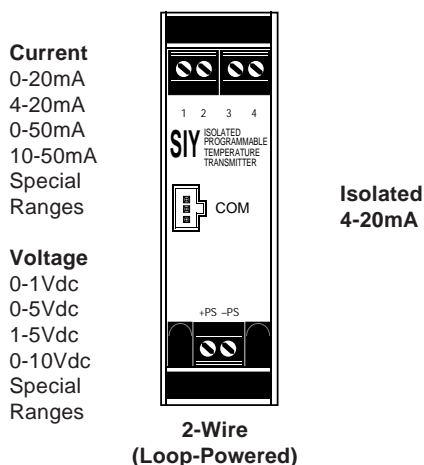

Specifications

<p>Performance Accuracy: $\pm 0.08\%$ of span (includes input accuracy, output accuracy, and the combined effects of linearity, hysteresis, repeatability, and adjustment resolution)</p> <p>Minimum Input Span: Current, 1mA; Voltage, 250mV</p> <p>Isolation: HPP housing, 1500Vrms input to output to case; DIN housing, 500Vrms input to output to case</p> <p>Measurement Cycle: Output updates 8 times per second</p> <p>Output Response: 256msec, maximum (128msec typical) for output to reach full scale response to a 10-90% step change on input</p> <p>Input Impedance: Voltage, 1MΩ; Current, 20Ω</p> <p>Ripple: 10mV peak-to-peak maximum (measured across 250Ω resistor)</p> <p>Load Effect (current outputs): Negligible within specified load limits</p>	<p>Performance (continued) Power Supply Effect: $\pm 0.002\%$ of span per 1V change</p> <p>Over-Voltage Protection: 48V maximum on output; 48V reverse polarity protection on output</p> <p>Maximum Input Overrange: Current: 100mA maximum continuous; Voltage on Current Input: ± 5Vdc peak; Voltage: 18Vdc</p> <p>Load Capability: Supply Voltage – 10V = Ω 0.02A</p> <p>Output Current Limiting: 3.8mA (low) and 21.4mA (high)</p> <p>Ambient Conditions Operating Range: –40°C to +85°C (–40°F to +185°F)</p> <p>Storage Range: –40°C to +85°C (–40°F to +185°F)</p> <p>Effect of Ambient Temperature on Accuracy: $\pm 0.015\%$ of span/°C</p>	<p>Ambient Conditions (continued) Relative Humidity: 0-95%, non-condensing</p> <p>RFI/EMI Immunity: 20V/m @ 20-1000MHZ, when tested according to SAMA standard 33.1 (10V/m @ 80-1000MHz, 1K AM, when tested according to IEC 1000-4-3-1995)</p> <p>Common Mode Rejection: 100dB, minimum, @ 50/60Hz</p> <p>Normal Mode Rejection: 60dB, typical, @ 1V peak-to-peak, 50/60Hz</p> <p>Adjustments The choice of a current or a voltage input is selected via the input terminals; all other settings are made using Windows-based configuration software</p> <p>Weight HPP-Style housing: 65 g (2.3 oz)</p> <p>DIN-Style Housing: 184 g (6.5 oz)</p> <p>LH1-Style Housing: Polyester Cover: 283.5 g (10 oz.) Metal Cover: 468 g (16.5 oz.)</p>
---	---	---

Ordering Information

Unit	Input	Output	Power	Options	Housing
SIY PC-Programmable Isolator/Converter	<p>PRG Programmable with supplied Configuration Software and front panel connection terminals for:</p> <p>CURRENT (into 20Ω): Any range between -2.5mA to 55mA including: 0-20mA 4-20mA 0-50mA 10-50mA (recommended minimum span, 1mA)</p> <p>VOLTAGE (into 1MΩ): Any range between -0.5 to 11V including: 0-5Vdc 1-5Vdc 0-10Vdc (recommended minimum span, 250mV)</p>	<p>4-20MA into 600Ω with 24Vdc power supply</p>	<p>10-42DC (loop- powered on output side)</p>	None Available	<p>DIN Universal, DIN-style aluminum housing mounts on 32mm G-type (EN50035) and 35mm Top Hat (EN50022) rails</p> <p>HPP Hockey-puck housing for mounting in standard connection and field-mount heads</p> <p>D2LS HPP in <i>D-BOX</i> enclosure with two ½-inch NPT entry ports and a solid cover</p> <p>D2LSP HPP in <i>D-BOX</i> enclosure with two ½-inch NPT entry ports and a solid cover with 2-inch pipe mount hardware</p> <p>CH4 HPP in cast iron, NEMA 4 head</p> <p>CH6 HPP in plastic, polypropylene (CH6) NEMA 4 head</p> <p>LH1NS‡ Connection head with two entry ports: ½-inch NPT cable and process-black PBT polyester cover</p> <p>LH1NA‡ Connection head with two entry ports: ½-inch NPT cable and process-black PBT polyester cover</p> <p>LH1MS‡ Connection head with two entry ports: ½-inch NPT cable and process-black aluminum cover</p> <p>LH1CS ‡Connection head with two entry ports: M20 Cable and G½ (BSP) process-black PBT polyester cover.</p> <p>* <i>D-BOX</i> housings with other entry port options are also available. Consult the factory for details.</p> <p>‡ Fifth designator in the LH1 housing description determines color. C=clear PBT polycarbonate; A=black aluminum; B=blue PBT polycarbonate; R=red PBT polycarbonate; Y=yellow PBT polycarbonate; G=green PBT polycarbonate; S=standard black PBT polycarbonate.</p> <p>NOTE: Add 'P' suffix to any LH or D housing for 2-inch pipe mounting hardware. i.e. D2LSP</p>

SIY Model Numbers—Ordering

To order additional or replacement transmitters for your application or system, refer to the Ordering Information table and “build” a model number using the information shown in bold text. Specify the following in order:

Unit / Input / Output / Power [Housing]

For a SIY in DIN-style housing, specify:

SIY / PRG / 4-20MA / 10-42DC [DIN]

For a SIY in a *D-BOX* enclosure with two ports and pipe mount hardware, order:

SIY / PRG / 4-20MA / 10-42DC [D2LSP]

Factory Calibration. To order a SIY factory-calibrated to a specific input range, contact your local Moore Industries Sales Representative. Provide the input range you require in the “Calibration Notes” section of the order. They will be happy to provide you with pricing information.

Accessories

Each shipment of SIY transmitters comes complete with the software and cables needed for configuration. To order additional or replacement parts, call your factory Sales Representative for the following part numbers:

- **Standard, Non-isolated Configuration Cable**, P/N 803-040-26. This cable is adequate for the majority of applications where the transmitter will be configured in the shop using a grounded, line-powered PC.
- **Optional, Isolated Configuration Cable**, P/N 803-039-26. This cable is for *in situ* field configuring. The cable is equipped with a self-powered input-to-output isolation circuit that protects the PC (typically a laptop or notebook) from possible damage due to high electrical potentials.
- **Configuration Software**, P/N 235-75120-01
- **Heads and Fittings**, Moore Industries offers a complete line of connection heads, enclosures, and fittings for use with the SIY. For more information, contact your local factory Sales Representative. Ask for datasheet #3.99.

Configuration & Bench Check

Configuration of the SIY consists of:

1. Checking to verify that the unit ordered is in fact the one received and that it has been correctly calibrated by the factory according to the order.
2. Installing the SIY Configuration Software.
3. Connecting the SIY to a PC and test setup and using **SETUP.EXE** to check for correct unit tagging, input type and range settings, and output zero/span trim.

Prior to shipment, our team of skilled technicians subjects every SIY to rigorous testing. *Every* product Moore Industries manufactures, sells, and services is guaranteed to meet the strict quality standards that our company demands.

Even if a unit has been configured to your specifications by the factory (factory calibration), it is a good idea to perform a bench check. In addition to providing a safe means of uncovering any unit damage that may have occurred during shipping, the procedures afford the user the opportunity of becoming familiar with SIY operation in a testing environment that is separate from the intended process or application.

Note:

The procedures in this section should be carried out in an environment considered appropriate for the general testing of electronic equipment, rather than in the field. Use a technician’s bench or similar, lab-type environment.

What You Will Need

To configure and bench check the SIY, you must first install, then run "SETUP.EXE". The PC used to configure SIY's should meet the following minimum specifications:

- 80386-based PC, or 100% compatible with hard disk
- 1.44Mb floppy diskette drive
- 1Mb free space on the hard disk
- 2Mb free RAM (Random Access Memory)
- Microsoft Windows® 3.1, '95®, '98®, or NT.

NOTE:

Windows '95®, '98®, or NT® may require a faster processor and more RAM to run the configuration software.

- 1 free (otherwise unused) serial port (COM 1, COM 2, COM 3, or COM 4) set to 4800 baud, with no parity, 8 data bits, and 1 stop bit

Also...

You will also need the equipment listed in Table 1 to perform the bench check of the unit itself. These materials are not provided by Moore Industries, but should be readily available in most labs and shops appropriate for configuring the SIY.

Table 1. SIY Configuration Equipment

Device	Specification
Current and/or Voltage Source	Accurate to $\pm 0.05\%$ of span for the intended application
Power Supply	10-42Vdc, $\pm 10\%$
Precision Load Resistor (optional)	250 Ω , $\pm 0.01\%$
Multimeter	Accurate to $\pm 0.025\%$

Note:

Be sure to use calibrated test equipment when performing the bench check and zero/span trim of the SIY.

Installing the SIY Software

Caution:

Make sure any background applications that you may be running on your PC (like antivirus software) are turned off before installing the SIY Configuration software.

To install the SIY Configuration software, insert the "Installation Disk" you received with your unit into your PC, then:

1. Using Windows® 3.1 Program Manager™ (the desktop), select "run" in the "file" pull-down menu. Enter:

"a:\setup.exe"

Where "a" designates the floppy drive with the diskette.

OR

Using Windows' 3.1 File Manager™, click on your floppy drive to access the files on the diskette, and double-click on "setup.exe".

OR

Using Windows 95, access the "Start" menu on your desktop, click "Settings", and finally "Control Panel". In this menu you will find the "Add/Remove Software" icon. Click on that and then on "Install".

2. The Windows installation program will prompt you for a source diskette, then a destination directory.

A status bar is displayed as the SIY program files are copied to the designated destination on your hard drive and expanded. When complete, the program displays the message shown in Figure 2.

Figure 2. SIY Configuration Software Installed Successfully



Bench Check Setup

Figure 3 shows a SIY hooked up to the equipment needed to perform the unit configuration, bench check, and output trim. Connect your SIY as shown in the figure and allow approximately 5 minutes for the setup to stabilize.

Note:

It is possible to run the SIY Configuration program without actually connecting a unit to the PC, but you will be unable to set a custom linearization table.

This makes it easy to devise and download a single configuration to several SIY's. Save the Configuration File to disk and connect the units in succession, downloading the same file to each.

Figure 3. Setting up the SIY for Configuration/Bench Check

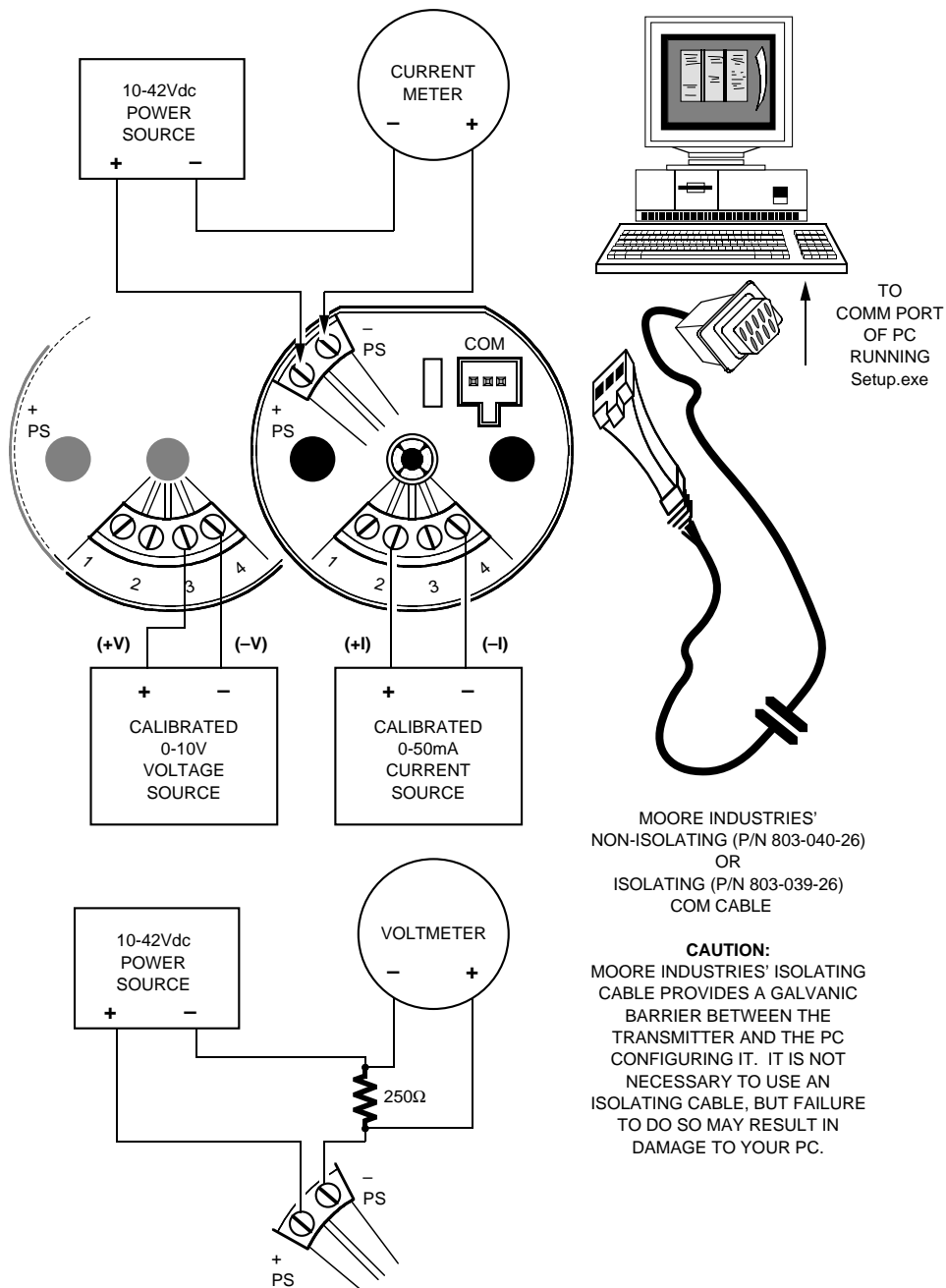

It is also possible to configure a SIY without connecting the unit to an input source. However, this makes it impossible to accurately trim the unit's output.

Using TR_SETUP.EXE

Once the software has been installed on your hard disk:

1. In Windows 3.1, double-click on "TRX/TRY/TDY/SIY Setup" in the SIY Program Group.

In Windows '95, '98, or NT, choose "TRX/TRY/TDY/SIY Setup" from the Programs in the Start menu.

2. Figure 4 shows the unit selection screen that appears when the setup program is started and the unit is not properly connected to the PC.

Figure 4. Choosing the SIY Setup

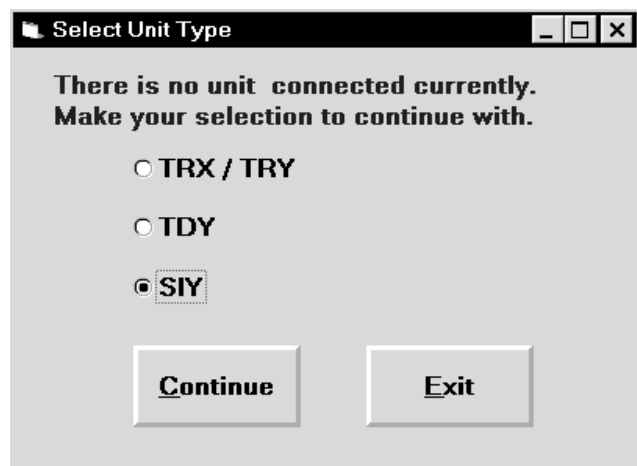

3. Set the values as appropriate for your intended SIY application in the various fields of the Configuration Screen in Figure 6.

Note:

If you are building a Configuration File without a SIY connected, the "SIY Status" section of the screen will be blank, and the "Communication" indicator will show steady on (as opposed to blinking).

During setup, the SIY tests the availability of COM Ports 1 through 4 in your system. The first available COM port is designated for SIY communications and is noted on the Configuration Screen. Your SIY communications cable must be connected to this port.

To connect the SIY to a port other than the default described above, disconnect the transmitter, then change the default selection with the pull down menu. Next reconnect the SIY communications cable.

4. When the Configuration File shown on the screen has been modified for your intended application, click "Stop" to stop measurement.

Figure 5. Accessing the Programming Functions of the Configuration Software

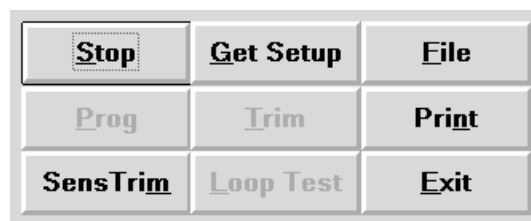

This will cause the "Prog" button to become available. Click "Prog", and the software will download the parameters on the PC into the non-volatile memory of the connected SIY.

Status of the downloading is shown in the upper left corner of the screen. When completed, the program beeps.

Note:

Changing the settings on the Configuration Screen does not change SIY parameters until the Configuration File is downloaded to SIY memory as described in Step 4 above.

Any time the SIY settings are changed, the configuration date will change to reflect the date the new settings were entered.

Figure 6. Setting SIY Parameters Using the Configuration Screen



Saving the SIY Configuration File to Disk

This is an optional procedure. You do not have to save the file to disk in order to download the file into SIY memory. Use this procedure to save information on the configuration of your SIY for downloading into other SIY transmitters, or for record-keeping purposes, etc.

To save the SIY configuration files to disk:

1. Click on "File" on the Configuration Screen to bring up the file management functions of the SIY Configuration Program.

The names of the buttons will change as shown in Figure 7. The "Status" section of the Configuration Screen will also change to show the default location on your hard disk for the storage and retrieval of SIY Configuration Files.

2. Click "Save" and enter the name for the Configuration File you are saving.
3. Enter the name of the file.

Note:

All SIY Configuration Files are saved with a ".siy" suffix.

Figure 7. Accessing the File Saving Functions of the SIY Configuration Program

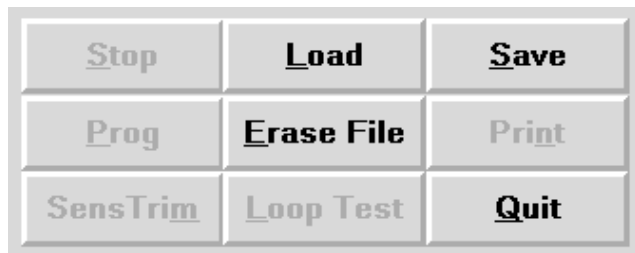

- Designate the drive and directory in which you wish to save the file.
- Click "Save File".

Note:

Clicking on the "Print" button will print the screen and provide a hard copy of the parameters set on the SIY.

- Click "Quit" to return to the SIY Configuration Screen.

Using a Configuration File Already on Disk

To download or edit a previously saved Configuration File you can use the "File" button on the SIY Configuration Screen to bring up a file from your hard disk or a floppy diskette.

To use a configuration file already on disk:

- Click "File" on the SIY Configuration Screen to bring up the File Management function of the program. The names of the buttons will change as shown in Figure 7.
- Click on the drive designator, directory, and/or file you wish to use (upper left area of the program screen).
- Click "Load".

The editable parameters on the rest of the Configuration Screen will change accordingly.

- When the Configuration File shown on the screen has been modified for your intended application, click "Stop" to stop measurement.

This will cause the "Prog" button to become available. Click "Prog", and the software will download the parameters on the PC into the non-volatile memory of the connected SIY.

Status of the downloading is shown in the upper left corner of the screen. When completed, the program beeps.

Note:

Changing the settings on the Configuration Screen DOES NOT CHANGE SIY PARAMETERS until the Configuration File is downloaded to SIY memory as described in Step 4, above.

Loading a Configuration File from a Connected SIY

To edit or view a Configuration File in the non-volatile memory of a connected unit, you can use the “Get Setup” function of the Configuration program.

Note:

Whenever a unit is correctly connected to your PC, the “SIY Status” section of the Configuration Screen will show the configuration data already stored in unit memory.

To load a configuration file from a SIY:

1. Make sure the SIY is connected properly. Check to make sure that the “Communication” light on the Configuration Program’s screen is blinking.
2. Click “Get Setup”.

The editable fields of the SIY Configuration Screen will change to match the data shown in the “Status” portion of the screen.

3. Continue with the procedure to edit the unit’s parameters, or save them to disk.

Setting Output Damping

To lessen the impact of your sensor’s step increases and decreases, you may want to set the damping time, which will cause the SIY to average out fluctuations over the set amount of time.

Setting the damping time is simple; simply click on the damping value bar under the “Output” portion of the screen (in the bottom-right corner), or click on the box to the right of the “Damping(sec)” area and type in a number between 0 and 20.032. See Figure 15 for an example of the Damping bar.

Trimming SIY Output

The SIY has a function that allows precise control over its output. Note that to activate this function, a unit must be connected in the setup to current meter, as shown in Figure 3.

To trim SIY output:

1. Set all unit parameters on the SIY Configuration Screen as required for your intended application.

When the Configuration File shown on the screen has been modified for your application, click “Stop” to stop measurement.

2. Click “Trim”.
3. Select and move the “Zero Scale Output” or the “Full Scale Output” slide bar to adjust the SIY output.

Monitor the output with a calibrated current meter or with a voltmeter measuring the drop across a precision, 250 Ohm resistor (see Figure 3).

While trimming, the Configuration Program will display a highlighted “Zero Scale Output Trim” or “Full Scale Output Trim” message, depending upon the parameter being set. The measured output will drop to zero output for zero trimming or will rise to full scale output for full scale trimming.

4. When both zero and full scale have been adjusted to satisfaction, press “Program Trim”, “Quit Trim”, then “Prog” to program the SIY with the new trim values.

Note:

Changing the settings shown on the screen in “Trim” mode DOES NOT CHANGE THE UNIT’S OPERATING PARAMETERS, it only updates the screen. The settings are saved to non-volatile memory by using the “Prog” function.

The “SIY Status” area of the Configuration Screen will reflect the new output settings being downloaded into unit memory.

Trimming the Input

Use this feature of the SIY to enhance the accuracy of the transmitter by precisely matching its actual reading of the input to its scaling of the 0% and 100% input settings. The Configuration program affords two methods for trimming input:

Note:

Trimming the input is NOT possible when the span is less than 1 volt. Moore Industries can factory configure the SIY to 250mV, but it cannot be trimmed at this setting.

Method 1

The recommended method is for the user to “capture” both zero and full scale input (presumably, using the actual sensor from the intended application).

Method 2

Alternatively, the user can capture *either* zero or full scale, and *enter* (type in) the complimentary value for zero and/or full scale directly into the Configuration File using the Zero and/or Full Scale entry boxes. This alternative method, while saving time and the effort of cycling the input between 0 and 100%, results in a slightly less accurate trim.

Note:

You must have a SIY connected and communicating with the Configuration Program, plus a source of input, to trim the SIY input.

The instructions assume that the Configuration Program has been loaded successfully. Make sure that the transmitter being trimmed is connected in the setup as shown in Figure 3, that the setup has stabilized (about 10 minutes), then:

1. Start the PC program “TRX_TRY_TDY_Siy Setup.exe”.

If the transmitter is connected properly, the program will automatically choose the correct type of Configuration File to open; TRY, TRX, SIY, or TDY, and after a brief display of a “splash” screen, show the Main Configuration Screen (see Figure 6, page 8).

2. Make sure the transmitter is communicating with the Configuration Program properly. Good PC-to-transmitter communication is indicated by the flashing yellow indicator on the Configuration Program screen, and by the message “SIY connected”.
3. **IMPORTANT:** *Make sure the Input Type and any scaling (input or output) showing in the “Input Status” section of the Configuration Screen matches the parameters showing on the rest of the screen.*

If the parameters do not match, program (download the parameters currently showing on the Configuration Screen) the connected SIY with the correct input type and configuration **before attempting to trim the sensor input.**

During the Trimming process, the transmitter “reads” the input, assuming that it is coming from the configured input type. If this information is not valid, any trim values subsequently loaded into the transmitter’s memory could result in significant inaccuracies during operation.

If all the parameters match, skip to Step 6.

If the parameters showing in the “Input Status” section of the Configuration Screen do not match the rest of the screen, click on “Get Setup” to load the transmitter settings into the Configuration Program from the transmitter’s memory.

4. Click on the “Program” button.
5. When the information on the “Input Status” section of the screen matches the parameters shown on the rest of the screen, click on the “Start” button. This enables the SIY whose input is being trimmed to begin monitoring the sensor or sensor simulator.
6. With the connected transmitter monitoring the source of input, click on the “SensTrim” button on the bottom of the screen.
7. Begin trimming by clicking on the “Sensor Trim ON” radio button. The “Zero Trim and “Full Trim” capture buttons will be enabled by this action.
8. To capture Zero Trim, go to Step 9. To capture Full Scale Trim go to Step 13.

- Adjust the input (from the sensor or simulator) to the SIY to the 0% level for the intended application.

Note:

*Make sure to monitor the input separately.
Do not use the input reading shown
on the Main Configuration Screen.*

- Allow the 0% input to stabilize (consult the manufacturer's documentation for the recommended stabilization period).
- Click on the "Zero Trim" button to capture the reading. After a brief pause, the captured input trim value is shown in the "Zero Captured" box of the Configuration Screen.

Figure 8. Trim Capture Box

Zero captured	Input Zero
-20.65	-20.65
ZeroTrim	
Full captured	Input Full
65.15	65.15
FullTrim	

- (OPTIONAL) Enter the Zero Scale Input value in the box shown in Figure 8. This is the offset value for the input in the transmitter's intended application. The user can choose from three courses of action at this point.

CHOICE A: Continue the Input Trimming process and capture the Full Scale Trim. Skip to Step 13.

This method takes time (since the input must be adjusted to the 100% level from the application), but produces the greatest accuracy. Moore Industries suggests using this method to achieve optimum SIY performance.

CHOICE B: Use the "Full Scale Input" setting as the "Full Scale Trim" value. Skip to Step 22.

This is a kind of "cheating" method, making it possible for the user to "trim" the full scale parameter for the 100% input without having to cycle the *actual* input to 100%. This method is not the preferred choice. It is inherently less accurate than capturing the actual 100% trim value (CHOICE A). It does, however, save time.

CHOICE C: Cancel the Input Trimming process altogether. Skip to Step 26.

- CHOICE A:** To continue trimming the input to the SIY using the readings taken from the sensor, adjust the actual input of the SIY to 100% of scale for the intended application.

Note:

*Make sure to monitor the input separately.
Do not use the input reading shown
on the Main Configuration Screen.*

- Allow the 100% input to stabilize (consult the manufacturer's documentation for the recommended stabilization period).
- Click on the "Full Trim" button to capture the reading. After a brief pause, the captured input trim value is shown in the "Full Captured" box.
- (OPTIONAL) Enter the value for the Full Scale Trim value in the "Input Full" box.
- Click on the "QuiSeTrim" button (Quit Sensor Trim).

The following message appears:

Figure 9. Sensor Trim Changed Dialog Box

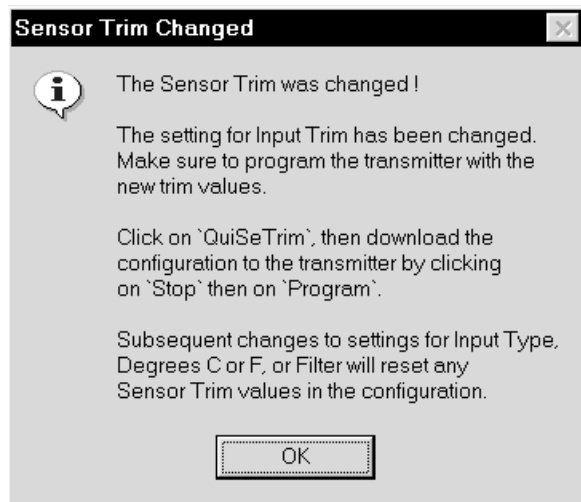

This is a reminder that it is necessary to program the connected transmitter before any of the trim values actually begin to function.

IMPORTANT:

Settings on the Configuration Program Screen do not take effect in the unit until the Configuration File is downloaded. Skip to Step 21 for instructions on getting the settings programmed into the SIY's nonvolatile memory.

18. Either:

- a. Download the settings for Input Type into the connected transmitter's memory (Go to Step 20),
- b. Continue creating a Configuration File by setting other parameters (Go to Step 22), or
- c. Save the current settings, including the Input Type into a file on disk for later downloading to a transmitter(s).

19. To start the Download Process, click on the "Stop" button at the bottom-center of the screen. This will enable the "Prog" button.
20. Click on the "Prog" button (Program), to download the settings (specifically, the input type and configuration) into the memory of the connected transmitter.

CAUTION:

*Any time a connected SIY is "programmed" by downloading a Configuration File into memory, ALL of the configuration parameters resident in the transmitter memory at the time of the download are **OVERWRITTEN**. These parameters are unrecoverable.*

This includes things like, tag name, calibration date, trim values, etc.

The Status Bar in the upper-left corner of the Configuration Program screen will display the progress of the download of the Configuration File to the connected transmitter.

When the download is complete, the Configuration Program will emit a faint, yet distinctly audible "boop" to indicate that the download was successful.

21. Click on the "Start" button to re-enable the Configuration Program's monitoring of the connected transmitter.

The status area of the Configuration Program screen will display the "Measurement ON" message, and will show the trimmed values resident in memory.

22. **CHOICE B:** Use the "Full Scale Input" setting as the "Full Scale Trim" value.

With the Zero Input Trimmed and Scaled, it is possible to enter a value in the "Full Scale Input" box, and to exit Input Trimming process now, using this entered value for the Full Scale Trim setting. This method, while less accurate, saves the time of having to cycle the input sensor from 0% to 100%.

Enter the desired 100% trim value in the "Full Scale Input" box.

23. Click on “QuitSeTrim” button. The following message appears:

Figure 10. Warning About Using the Full Scale Input for Trimming

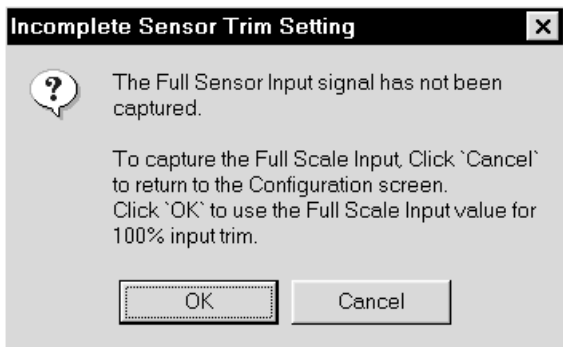

24. To return to the Input Sensor Trimming Process or to Cancel all Input Sensor Trimming, skip to Step 26.

To quit the Input Sensor Trimming process with the captured Zero Trim intact and the Full Scale Trim taken from the entered Full Scale Input, click “OK”. The message from Figure 10 then appears.

This is a reminder that it is necessary to program the connected transmitter before any of the trim values actually begin to function.

IMPORTANT:

Settings on the Configuration Program Screen do not take effect in the unit until the Configuration File is downloaded.

25. Either:
- Download the settings for Input Type into the connected transmitter’s memory (Go back to Step 19), or
 - Save the current settings, including the Input Type into a file on disk for later downloading to a transmitter(s).
26. **CHOICE C:** To quit the Input Sensor Trim process without setting up any trim parameters, click on the “QuitSeTrim” button.

Note:

To return to the Input Trimming process, click “OK”, then re-enter the Input Trimming process (Step 7). Otherwise, continue with Step 27.

27. Click “Cancel”.
This returns the program to the Main Screen.
28. Click on the “Sensor Trim OFF” button:
29. Either:
- Download the settings for Input Type into the connected transmitter’s memory (Go back to Step 19), or
 - Save the current settings, including the Input Type into a file on disk for later downloading to a transmitter(s).

Verifying Input Trim

Use this procedure to make sure that the SIY transmitter that was trimmed using the procedure starting on page 11 is functioning within rated specifications.

1. Make sure the transmitter being checked is connected to the equipment listed in Table 1 (page 5) as shown in Figure 3 (page 6).

Make sure that the setup has had time to stabilize (about 10 minutes), and that the transmitter and the PC are communicating properly.

2. Start the PC program "TRX_TRY_TDY_SIY Setup.exe".

If the transmitter is connected properly, the program will automatically choose the correct type of Configuration File to open from the list: TRY/TRX, TDY, or SIY.

3. Make sure the transmitter is communicating with the Configuration Program properly. Good PC-to-transmitter communication is indicated by the flashing indicator on the Configuration Program screen, and by the message "SIY connected".

4. Click on the "Get Setup" button on the bottom of the Configuration Program screen.

This loads the parameters from the transmitter's memory. The settings for input trim and scaling shown on the right side of the Configuration Program screen should match those shown on the left side of the screen in the "Status" section.

5. Adjust the input to the SIY to the zero percent level of the selected range.
6. Note the SIY reading of the input shown in the "Input" box of the Configuration Program.
7. Calculate the 50% level for the selected range, and adjust the input to that point.
8. Repeat Step 6.
9. Adjust the input to the 100% level of the selected range.
10. Repeat Step 6.

If, after completing the procedure for trimming the input, the transmitter is still performing outside the listed accuracy parameters, consult the factory.

Creating a Custom Linearization Table

The SIY supports user-defined linearization of both volt and current inputs. Up to 85 input/output points can be defined, and the user can also specify the format and engineering units of the output (viewable with the Configuration Program).

This section explains how to create a Custom Linearization Table for downloading into SIY memory.

The instructions assume that the Configuration Program has been loaded successfully. Moore Industries also suggests saving the initial settings resident in the transmitter before making any changes.

To create a Custom Linearization Table:

1. Start the PC program “TRX_TRY_TDY_SIY V3.0 Setup.exe”.

If the transmitter is connected properly, the program will automatically choose the correct type of Configuration File to open: TRY, TRX, TDY, or SIY. After a brief display of a “splash” screen, the Main Configuration Screen will appear.

Note:

*It **IS NECESSARY** to connect a unit to the PC in order to create a Custom Linearization Table.*

2. If the Configuration software recognizes your SIY, skip to step 4.
3. If the transmitter is not located, check the cables attached to the SIY and make sure that the power is plugged in.

4. With the Configuration Program Main Screen showing, click on the pull-down menu for “Input Type”, and select whether you want “VOLTS” or “CURRENT”.
5. Use the pull-down menu to set “Linearization ON”. This enables the “CustTabl” button in the lower-left area of the Configuration Main Screen.

Figure 11. Linearization Must be set to ON to Create a Custom Table

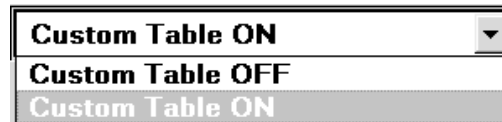

6. Click on the “CustTabl” (Customize Linearization Table) button.

Figure 12. Clicking on “Custom Table” Enables the Linearization Function.



This causes the Configuration Program to change its upper-right corner area to accommodate the table.

Figure 13. Example, The Custom Linearization Table

Custom Tables		
Point	Inp mA	Out EGU
1	-1.111	1.50
2	-1.000	2.25
3	-0.500	3.00
4	0.000	3.75
5	0.500	4.50
6	1.160	5.25
7	1.700	6.00
8	2.200	6.75
9	2.700	7.50
10	3.200	8.25
11	3.700	9.00

Custom Table File: CURR.BIN

EGU Output Format Points

- Use the table fields to set values for input and output from the transmitter's intended application.

Use the Up, Down, Left, and Right arrow keys on the PC keyboard to move the cursor among the cells in the table.

- Use the "Restore" button to reset the table.

Caution:

Restoring the configuration file erases any values in the table, overwriting them with whatever is stored in the most recent file.

Use the "Save" button to save the table.

Use the "Delete" button to delete the file and all its values from the PC disk/memory.

- Use the "EGU" field to set the Engineering units of the readout from the transmitter when connected to the Configuration Program.
- Set the "Output Format" field to the desired resolution using the pull-down menu.
- Enter the number of points to use to constitute the Linearization Table in the "Points" field.

The Rules for Custom Linearization:

- The values entered in either column must be sequential. That is, numbers CANNOT go "1" followed by "3" followed by "1.765" followed by "3.5" followed by "2", etc.
- The difference between any consecutive values in the table (in either column) must be less than 50% of the entire configured range.
- One "Output EGU" value per "Input mV" value only.
- It is not necessary to use all 85 available points, but the first and last points in the curve always default to the 0% and 100% input scale (input range).
- If you decide not to use all 85 points, you must change the number of points in the "Points" field to the number you wish to use.

Note:

Moore Industries suggests filling in the EGU (Engineering Units), then the number of points, and finally the values in the table.

- When the table is complete, click on the “Save” button to keep a copy of it on disk for future reference/download.

Caution:

To make the Linearization Table entered available for downloading to a connected SIY, the file **MUST** be saved before quitting the Custom Linearization process.

- Click on “QuitTable” to stop adding Linearization Values.

Caution

Quitting the Linearization process before saving the table erases any values entered.

Figure 14. Click on “Quit Table” to Stop Customizing Linearization Values



The upper-right area of the Configuration Screen will return to normal.

- Click on the “Prog” (Program) button to download the output trim settings into the transmitter memory.

CAUTION:

Any time a connected SIY is “programmed” by downloading a Configuration File into memory, ALL of the configuration parameters resident in the transmitter memory at the time of the download are **OVERWRITTEN**.

This includes things like: tag name, calibration date, trim values, etc.

Once a transmitter’s memory is “erased” in this fashion, the old operating parameters are unrecoverable, and will have to be regenerated from scratch if needed again.

Scaling the SIY Output

To scale the transmitter’s output, use the mouse to move the slider bars in the “Output” section of the Main Configuration screen. “Zero Scale Output” effects the zero output, and “Full Scale Output” effects full scale output.

Note:

The SIY Output Scaling function will not operate unless a SIY is connected in the calibration setup shown in Figure 3.

Setting Zero higher than Full Scale causes a “Reverse Output” message to appear on the screen above the section. Setting the SIY to function in this manner will cause its output to increase as input falls, and vice-versa.

Figure 15. An example of Reversed Output

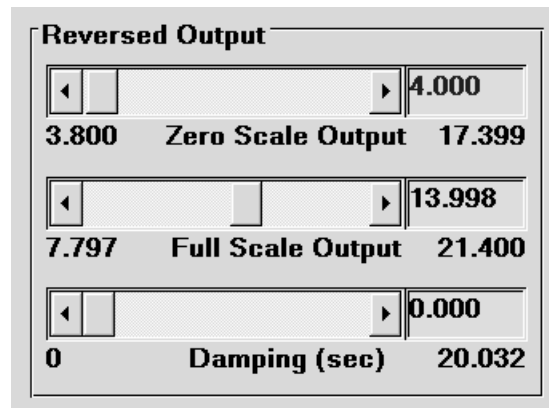

Note:

Changing the scaling on the SIY Main Configuration screen **DOES NOT** affect actual SIY output until the Configuration File shown on the screen during scaling is downloaded into unit memory. You must use the “Prog” function to complete the Output Scaling operation.

Getting Help

The SIY Configuration Program is equipped with a context-sensitive help system that you can activate at any time while using "TR_SETUP.EXE".

To enable Help, click on "Help" in the window on the bottom edge of the Configuration Screen.

The window will then display descriptions about the field the pointer is positioned over.

For more help, click on the "About" button in the lower-right corner of the screen. This will display the telephone numbers at which you can contact Moore Industries' trained staff of Customer Service Technicians for assistance.

Installation

The SIY transmitter is available in either the HPP hockey-puck housing style or the compact, universal, DIN-style housing.

The HPP housing includes a metal mounting plate secured to the bottom. The case is designed to fit inside the popular 30-35 mm connection head. The DIN-style housing can be mounted on either 32 mm, G-type DIN rail (EN50035), or 35mm, Top Hat rail (EN50022). The DIN-housed unit is also equipped with removable terminal blocks.

Figure 16 shows the dimensions of the HPP housing. The dimensions of the DIN-style SIY are shown in Figure 17.

Mounting and Connections

Moore Industries suggests installing the SIY by first mounting the unit in its intended application, then making the electrical connections to input, output, and power.

Before any installation, make sure that the unit has been bench checked to ensure that it is configured and calibrated for its intended application.

Mounting the HPP-Housed SIY

To mount the SIY, use 4.5mm (0.18 in) screws to connect the SIY and mounting plate to a connection head or other housing.

Mounting the DIN-Housed SIY

To mount the SIY on Top Hat DIN rail, seat the upper extrusion on the back panel over the top of the rail and pivot downward until the housing locks into place.

To mount the unit on G-type rail, seat the extrusion under the top lip of the rail and pivot downward.

Electrical Connections for the HPP-Housed SIY

Figure 18 shows the hookups for the SIY when in their HPP housing configuration. Feed the sensor wiring up through the center thru-hole (and typically, out a side port of the connection head).

Electrical Connections for the DIN-Housed SIY

Figure 19 shows the hookups for the SIY in DIN-style housing. Refer to the section on ground wiring practices when installing this type of transmitter.

Ground Wiring Recommendations

Moore Industries recommends the following ground wiring practices:

- Any Moore Industries product in a metal case or housing should be grounded.
- All input signals to, and output signals from, Moore Industries' products should be wired using a shielded, twisted pair technique. Shields are to be connected to an earth or safety ground at the unit itself.
- The maximum length of any unshielded input and/or output signal wiring is two inches.

Figure 16. Dimensions of the HPP version of the SIY

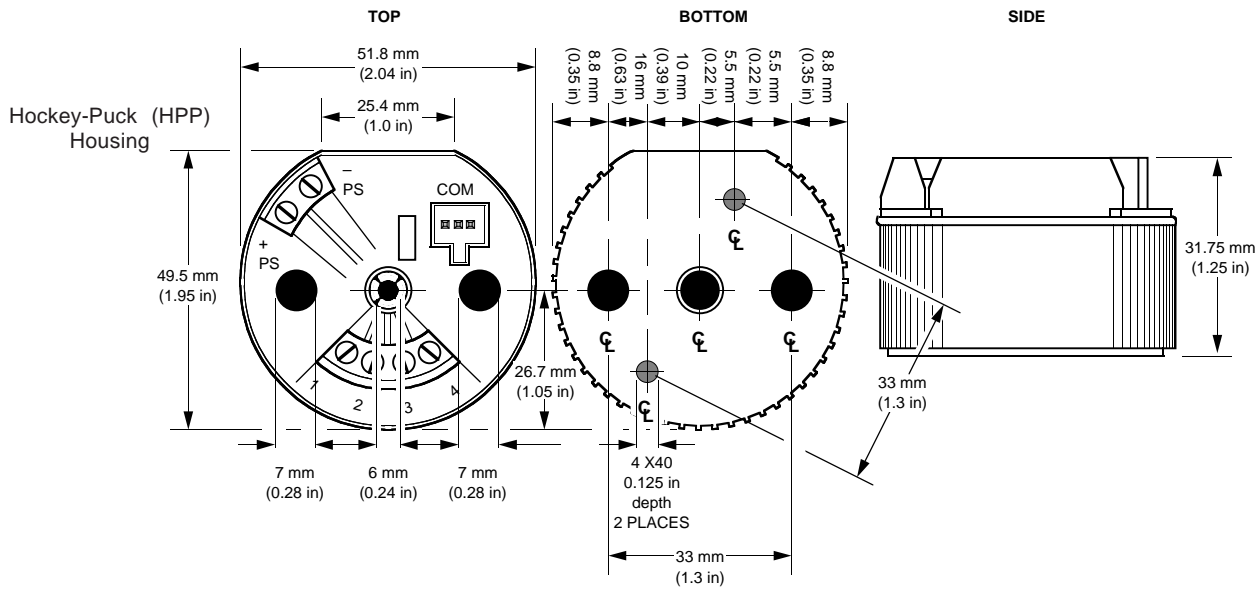
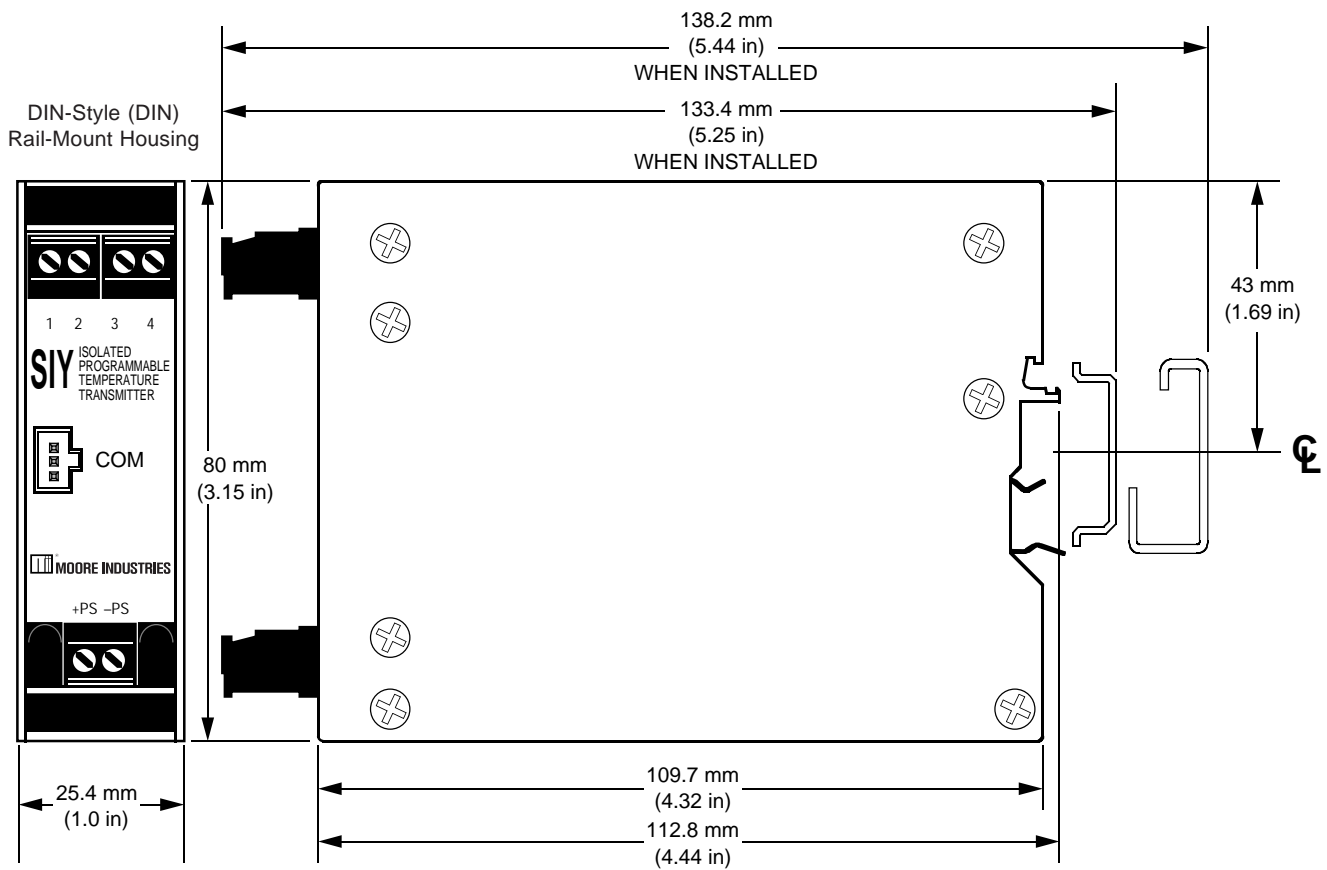

Figure 17. Dimensions of the DIN-style version of the SIY



CE Conformity

Installation of any Moore Industries products that carry the CE certification (Commission Electro-technique) **must** adhere to guidelines set forth in applicable EMC (Electromagnetic Compatibility) directives (EN55011, EN 50082-1, EN50082-2, etc.) Consult the factory for the most current information on products that have been CE certified.

Operation

Once programmed, calibrated, installed, and supplied with the correct power, SIY transmitters begin to operate. Depending upon environmental conditions, they can be expected to continue to operate unattended for extended periods of time.

Maintenance

Moore Industries suggests you perform a quick check for terminal tightness and general unit condition every 6-8 months. Always adhere to any site requirements for programmed maintenance.

Troubleshooting

If a transmitter's performance begins to deteriorate noticeably and a physical check of the installation uncovers no adverse conditions or damage, remove the unit from service and perform the calibration procedures listed earlier in this manual. Check in particular the Trim Output procedure.

Figure 18. Connecting the HPP-Housed SIY

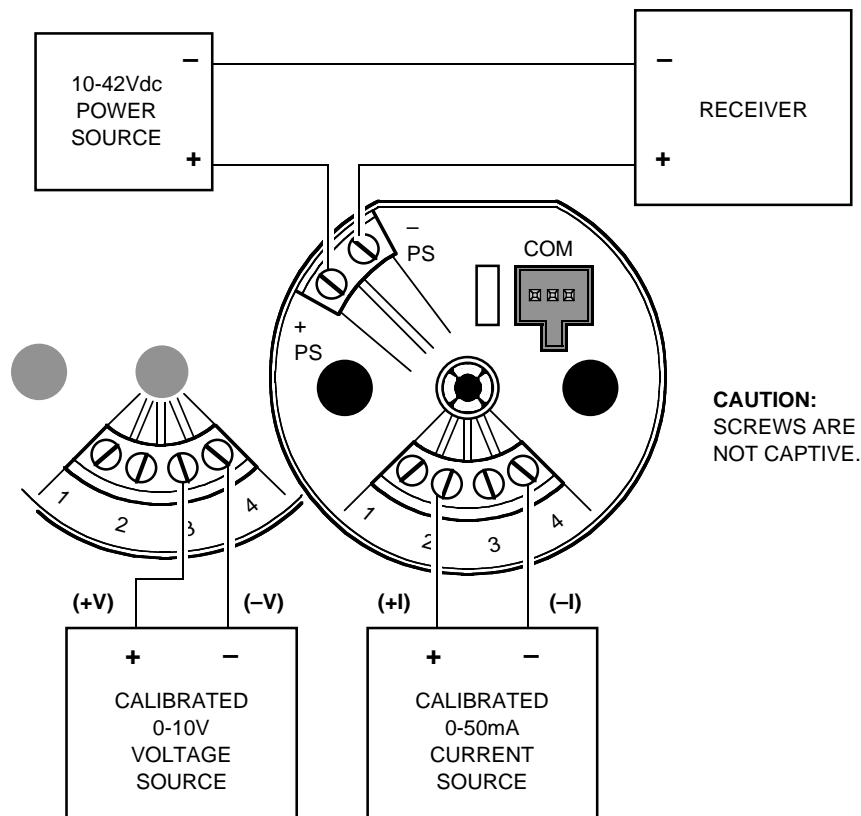
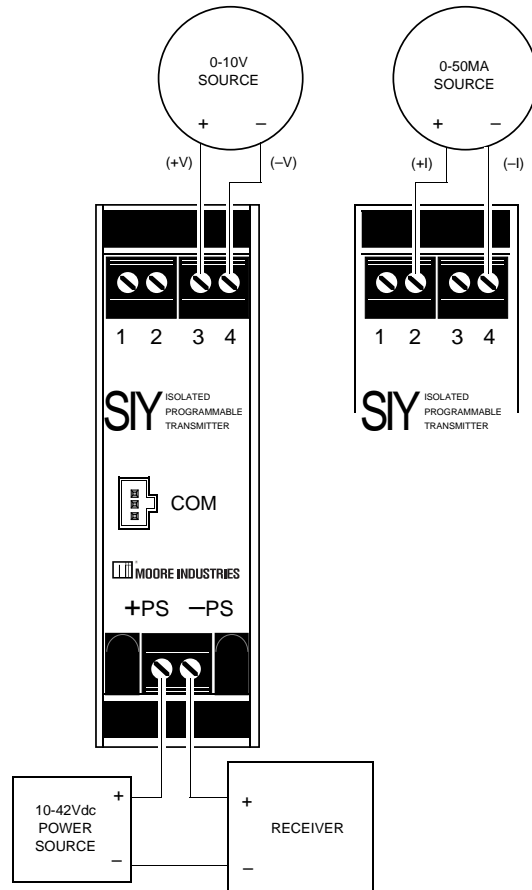

Figure 19. Connecting the DIN-Housed SIY



Customer Support

Moore Industries is recognized as the industry leader in delivering top quality to its customers in products and services. We perform a battery of stringent quality assurance checks on every unit we ship. If any Moore Industries product fails to perform up to rated specifications, call us for help. Our highly skilled staff of trained technicians and engineers pride themselves on their ability to provide timely, accurate, and practical answers to your process instrumentation questions. Factory phone numbers are on the back cover.

If problems involve a particular SIY, there are several pieces of information you can gather **before** you call the factory that will help our staff get you answers more efficiently. When you call, please have:

- The model number of the unit in question.
- The serial number of the unit in question.
- The job number (if available).
- The purchase order under which the unit was shipped (if available).

Moore Industries

STAR
CENTER

*Providing Instrumentation fast
from our Quick-Ship Facilities!*

- Signal Transmitters
- Temperature Transmitters
- I/P and P/I Converters
- Isolators and Converters
- Distributed I/O and Data Communications
 - Alarm Trips
- Integrators and Totalizers
 - Power Transducers
- Instrument Power Supplies
- Racks, Rails, and Enclosures



IN
STOCK



READY
TO
SHIP



FAST
REPAIRS
TOO!

*If you need it today—It's on its way!
Call us NOW.*

United States
1-800-999-2900

United Kingdom
0800 525107

Australia
(02) 9525-9177



RETURN PROCEDURES

To return equipment to Moore Industries for repair, follow these four steps:

1. Call Moore Industries and request a Returned Material Authorization (RMA) number.

Warranty Repair –

If you are unsure if your unit is still under warranty, we can use the unit's serial number to verify the warranty status for you over the phone. Be sure to include the RMA number on all documentation.

Non-Warranty Repair –

If your unit is out of warranty, be prepared to give us a Purchase Order number when you call. In most cases, we will be able to quote you the repair costs at that time. The repair price you are quoted will be a "Not To Exceed" price, which means that the actual repair costs may be less than the quote. Be sure to include the RMA number on all documentation.

2. Provide us with the following documentation:
 - a) A note listing the symptoms that indicate the unit needs repair
 - b) Complete shipping information for return of the equipment after repair
 - c) The name and phone number of the person to contact if questions arise at the factory
3. Use sufficient packing material and carefully pack the equipment in a sturdy shipping container.
4. Ship the equipment to the Moore Industries location nearest you.

The returned equipment will be inspected and tested at the factory. A Moore Industries representative will contact the person designated on your documentation if more information is needed.

The repaired equipment, or its replacement, will be returned to you in accordance with the shipping instructions furnished in your documentation.

WARRANTY DISCLAIMER

THE COMPANY MAKES NO EXPRESS, IMPLIED OR STATUTORY WARRANTIES (INCLUDING ANY WARRANTY OF MERCHANTABILITY OR OF FITNESS FOR A PARTICULAR PURPOSE) WITH RESPECT TO ANY GOODS OR SERVICES SOLD BY THE COMPANY. THE COMPANY DISCLAIMS ALL WARRANTIES ARISING FROM ANY COURSE OF DEALING OR TRADE USAGE, AND ANY BUYER OF GOODS OR SERVICES FROM THE COMPANY ACKNOWLEDGES THAT THERE ARE NO WARRANTIES IMPLIED BY CUSTOM OR USAGE IN THE TRADE OF THE BUYER AND OF THE COMPANY, AND THAT ANY PRIOR DEALINGS OF THE BUYER WITH THE COMPANY DO NOT IMPLY THAT THE COMPANY WARRANTS THE GOODS OR SERVICES IN ANY WAY.

ANY BUYER OF GOODS OR SERVICES FROM THE COMPANY AGREES WITH THE COMPANY THAT THE SOLE AND EXCLUSIVE REMEDIES FOR BREACH OF ANY WARRANTY CONCERNING THE GOODS OR SERVICES SHALL BE FOR THE COMPANY, AT ITS OPTION, TO REPAIR OR REPLACE THE GOODS OR SERVICES OR REFUND THE PURCHASE PRICE. THE COMPANY SHALL IN NO EVENT BE LIABLE FOR ANY CONSEQUENTIAL OR INCIDENTAL DAMAGES EVEN IF THE COMPANY FAILS IN ANY ATTEMPT TO REMEDY DEFECTS IN THE GOODS OR SERVICES, BUT IN SUCH CASE THE BUYER SHALL BE ENTITLED TO NO MORE THAN A REFUND OF ALL MONIES PAID TO THE COMPANY BY THE BUYER FOR PURCHASE OF THE GOODS OR SERVICES.

ANY CAUSE OF ACTION FOR BREACH OF ANY WARRANTY BY THE COMPANY SHALL BE BARRED UNLESS THE COMPANY RECEIVES FROM THE BUYER A WRITTEN NOTICE OF THE ALLEGED DEFECT OR BREACH WITHIN TEN DAYS FROM THE EARLIEST DATE ON WHICH THE BUYER COULD REASONABLY HAVE DISCOVERED THE ALLEGED DEFECT OR BREACH, AND NO ACTION FOR THE BREACH OF ANY WARRANTY SHALL BE COMMENCED BY THE BUYER ANY LATER THAN TWELVE MONTHS FROM THE EARLIEST DATE ON WHICH THE BUYER COULD REASONABLY HAVE DISCOVERED THE ALLEGED DEFECT OR BREACH.

RETURN POLICY

For a period of thirty-six (36) months from the date of shipment, and under normal conditions of use and service, Moore Industries ("The Company") will at its option replace, repair or refund the purchase price for any of its manufactured products found, upon return to the Company (transportation charges prepaid and otherwise in accordance with the return procedures established by The Company), to be defective in material or workmanship. This policy extends to the original Buyer only and not to Buyer's customers or the users of Buyer's products, unless Buyer is an engineering contractor in which case the policy shall extend to Buyer's immediate customer only. This policy shall not apply if the product has been subject to alteration, misuse, accident, neglect or improper application, installation, or operation. THE COMPANY SHALL IN NO EVENT BE LIABLE FOR ANY INCIDENTAL OR CONSEQUENTIAL DAMAGES.



The Interface Solution Experts • www.miinet.com

United States
Tel: (818) 894-7111
FAX: (818) 891-2816

Australia
Tel: (02) 9525-9177
FAX: (02) 9525-7296

Belgium
Tel: 03/448.10.18
FAX: 03/440.17.97

The Netherlands
Tel: (0)344-617971
FAX: (0)344-615920

United Kingdom
Tel: 01293 514488
FAX: 01293 536852