

July 2002
235-745-00 E

Smart HART Temperature
Transmitters & Displays

Smart HART Temperature
Transmitters & Displays

THZ & TDZ

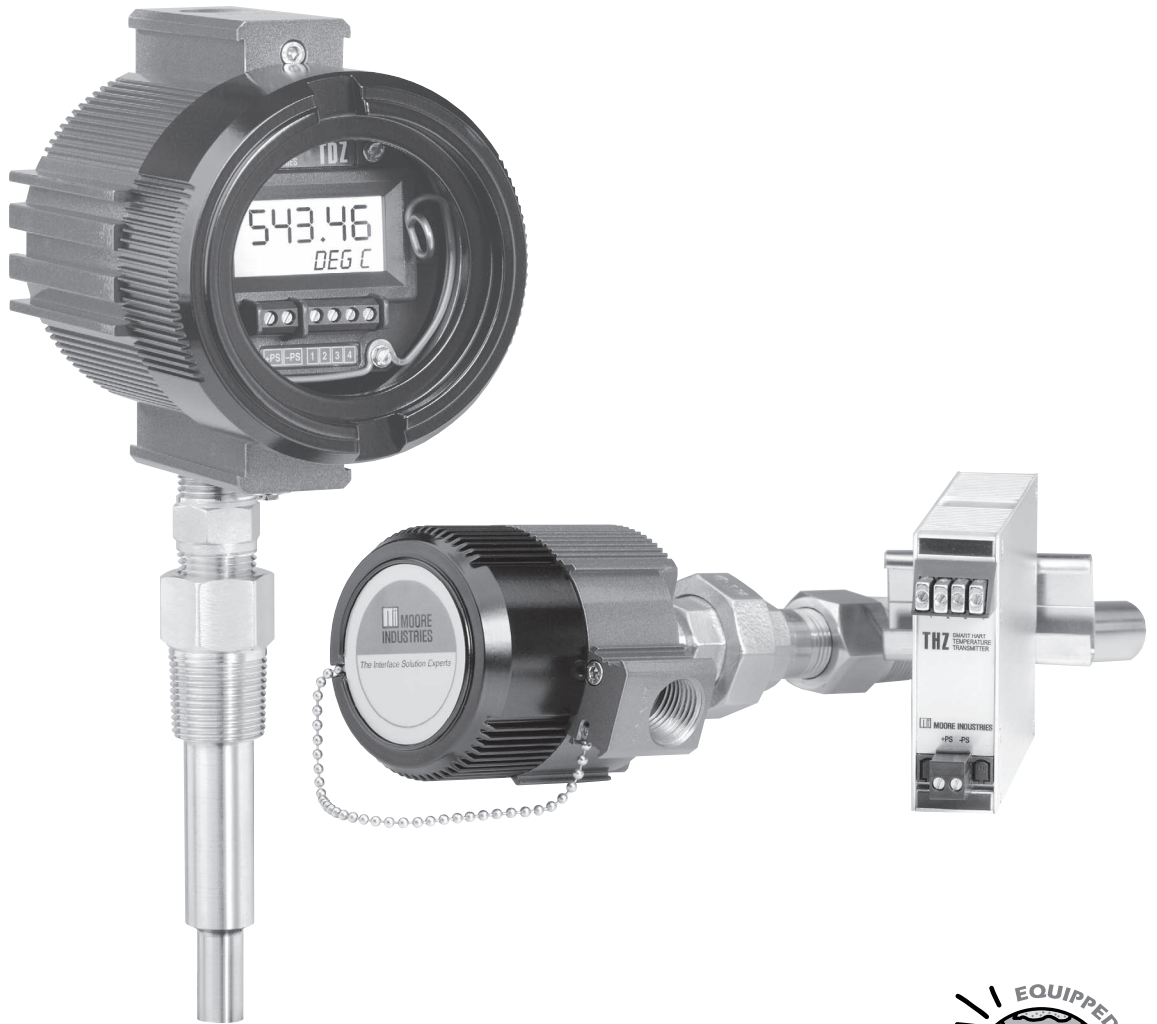



HelpMap

Navigation System

The THZ and TDZ Intelligent PC Configuration Software is equipped with our new HelpMap Navigation System. This searchable, comprehensive help system includes all the tables and illustrations you will need to easily setup your unit—from startup to hookup. Reference the HelpMap if you are looking for more detailed information than is provided in this manual. Simply install and run the PC Configuration Software, then click on the questionmark button in the upper right corner of the PC Configuration Program.

Table of Contents

Introduction	1
The THZ & TDZ	1
Model and Serial Numbers	1
Specifications	2
Input Type & Accuracy Table	3
Ordering Information	4
Additional Parts	4
Dimensions	5-9
Configuring a THZ or TDZ	9
Installing the Configuration Software	10
Connecting the THZ or TDZ to the PC	10
Necessary Equipment Table	10
Using the PC Configuration Program	11
Using the HART Communicator	13
Programming when a Device Description is Available	13
The HART Communicator Menu with a Device Description	15
The HART Communicator Menu without a Device Description	17
Installation	18
Operation	19
Customer Support	19
Troubleshooting the PC Software	20
Appendix A: Intrinsic Safety	21



Introduction

This is the users' manual for Moore Industries' family of Smart HART Temperature Transmitters. It contains all of the information needed to configure, install, operate, and maintain the THZ and TDZ. In many cases, more detailed information is provided through the HelpMap portion of the configuration software. (Run the Configuration Software then press the questionmark button on the upper-right side of the screen.) If you would like additional assistance, call one of our STAR centers.

The following guidelines are used in this manual:

WARNING - Hazardous procedure or condition that could injure the operator.

Caution - Hazardous procedure or condition that could damage or destroy the unit.

Note - Information that is helpful for a procedure, condition, or operation of the unit.

The THZ & TDZ

The THZ and TDZ are 2-wire (loop-powered), user-configurable, HART®-based temperature transmitters. Typically paired with a complete temperature assembly from our extensive line of durable housing and enclosure options. Their size, accuracy, and compatibility make them the ideal solution when measurements must be made in remote or otherwise difficult-to-access locations.

Model and Serial Numbers

Moore Industries uses a system of model and serial numbers to keep track of all of the information on every unit it sells and services. If a problem occurs with a THZ or TDZ, check for a tag affixed to the unit listing these numbers. Supply the Customer Support representative with this information when calling.

Figure 1. The THZ and TDZ Smart HART Temperature Transmitters' remotely programmable input and combination analog/digital output make it the perfect answer to problems encountered when interfacing control room equipment and field sensors.

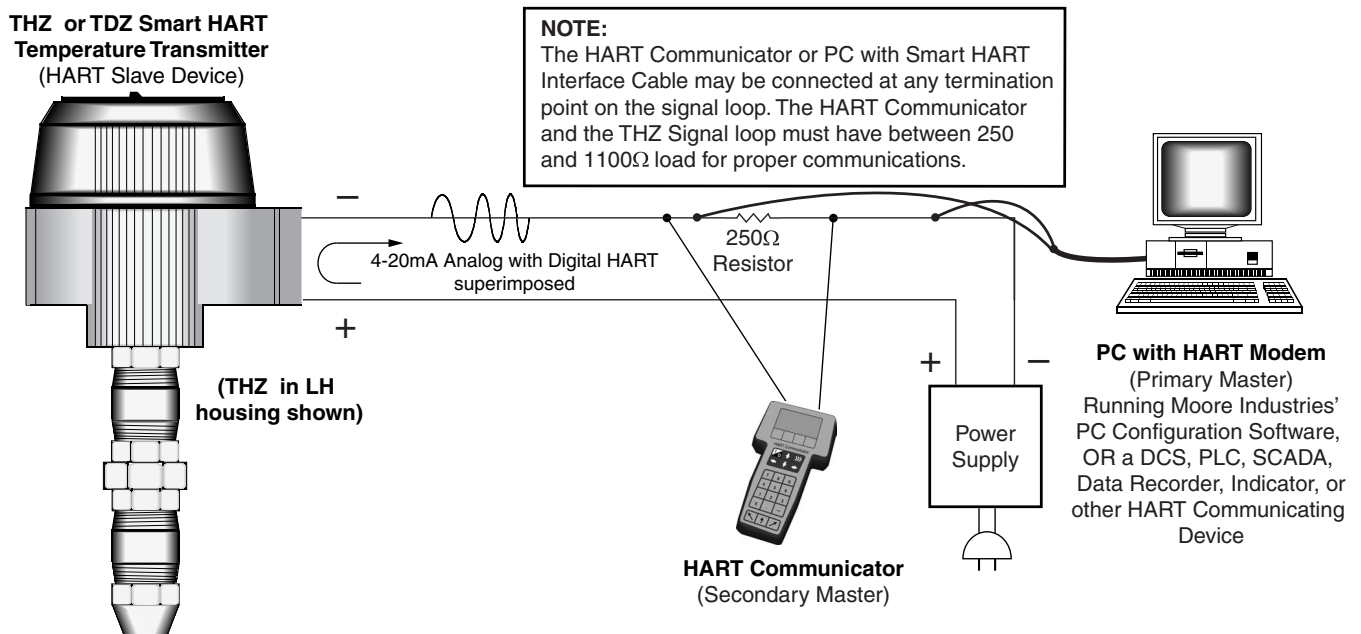

THZ & TDZ

Specifications

<p>HART Specifications Address Range: 0-15 (1-15 are for multidrop loops) Transmission Speed: 1200 baud Character Format: 1 Start Bit - 8 Data Bits - 1 Odd Parity Bit - 1 Stop Bit</p>	<p>Performance (Continued) Digital Input Filter: User-programmable; 50/60 Hz Power Supply Effect: ±0.002% of span per 1V change Load Effect: Negligible within specified power limits Load Capability: Load = $\frac{(V_{dc} - 12)}{0.024}$ Burnout Protection: User-programmable, Upscale to 23.6mA; Downscale to 3.6mA Output Current Limiting: 3.8mA and 21.6mA for input over range; 25mA maximum T/C Input Impedance: 40MΩ, nominal RTD & Ω Excitation: 250μA ±10% RTD Lead Wire Resistance Maximum: RTD resistance + 2X lead wire resistance < 4000Ω; Recommended lead wire resistance for three wire connections: <35Ω/wire; 10Ω copper sensor <5Ω Sensor Lead Resistance Effect: 1.0Ω in reading/Ω of lead resistance for 2-wire sensors; 1.0Ω in reading/Ω of lead of unbalanced resistance for 3-wire sensors; no effect on 4-wire sensors Damping: User set; 0-30 seconds Resolution: Input, 20-bit; Output, 16-bit Supply Range: 12-28V I.S.; 12-42V normal operation</p>	<p>Display (Continued; THZ [DH] & TDZ only) Decimal Points: Automatically adjusting decimal point with a two decimal-place maximum (Analog output display is always two decimal places) Range: -99999 to 99999 Minimum Display Span: 1.00</p>
<p>Performance Input Accuracy: Refer to Table 1 (page 3) Analog Output Accuracy: ±0.015% of span Overall Accuracy: The overall accuracy of the unit is the combined input and output accuracy. It includes the combined effects of linearity, hysteresis, repeatability, and adjustment resolution. It does not include ambient temperature effect. For T/C input only, add the Reference Junction Compensation error Reference Junction Compensation: ±0.45°C (±0.81°F) Stability: see Table 4 Isolation: THZ: HPP, 1000Vrms input-to-output continuous; DIN, 500Vrms input-to-output continuous; THZ [DH] & TDZ: 500Vrms input-to-output continuous, and will withstand a 500VAC dielectric strength test for one minute without breakdown Response (Rise) Time: 100 msec maximum for the output to change from 10% to 90% for an input step change of 0% to 100% Step Response Time: THZ: 600 msec maximum, 500 msec typical from the time an input is applied to the output reaching 90% of its final value; THZ [DH] & TDZ: 700 msec maximum, 500 msec typical from the time input is applied to the output reaching 90% of its final value Ripple: Less than 10mV peak-to-peak measured across a 250-ohm load resistor at frequencies up to 120Hz Over-voltage Protection: Input, ±5Vdc peak, maximum; Output, 48Vdc, maximum</p>	<p>Display (THZ [DH] & TDZ only) Type: THZ [DH]; Top Row, 18mm (0.5 inch) high black digits on a reflective background; Bottom Row, 10mm (0.4 inch) high digits on a reflective background; Two-digit HART address indicator; % of Span shown on a bar graph with upper and lower out-of-range indicators; TDZ; Top Row, 10mm (0.4 inch) high black digits on a reflective background; Bottom Row, 6mm (0.225 inch) high digits on a reflective background; Two-digit HART address indicator Format: Two rows of five alphanumeric characters</p>	<p>Ambient Temperature Operating & Storage Range: -40°C to +85°C (-40°F to +185°F) Relative Humidity: 0-95%, non-condensing Ambient Temperature Effect: See Tables 2 & 3 Effect on Reference (Cold) Junction Compensation: ±0.005°C per °C change of ambient temperature RFI/EMI Immunity: THZ: HPP 10V/M, and DH, DIN 30V/M when tested according to SAMA 33.1 abc with 0.5% of span or less error; 10V/M @ 80-1000MHz, 1KHz AM when tested according to IEC 1000-4-3-1995; TDZ: 20V/M when tested according to SAMA 33.1 abc with 0.5% of span or less error; 10V/M @ 80-1000MHz, 1 KHz AM, when tested according to IEC 1000-4-3-1995 Startup Time: Performance within specification 8 seconds after power is applied Noise Rejection: Common mode, 100dB @ 50/60Hz; Normal Mode: 70dB typical at 200mV peak-to-peak @ 50/60Hz</p>
		<p>Weight THZ DIN: 221 grams (7.9 oz) THZ HPP: 101 grams (3.6 oz) THZ HPP in LH1: 434 grams (15.5 oz) THZ HPP in LH2: 654 grams (1 lb., 7.3 oz) THZ DH: 1.75kg (3 lb, 14.5 oz) TDZ HP: 188 grams (6.7 oz) TDZ HP in BH2NG: 1.42 kg (3 lbs., 2.5 oz) TDZ HP in D-BOX: 678 grams (1 lb., 7.7 oz)</p>

Specifications and information subject to change without notice.

Table 1. Input Types, Ranges, Minimum Span and Maximum Range Specifications, and Accuracy of the THZ and TDZ

Input	Type	α	Ω	Conformance Range	Minimum Span	Input Accuracy	Maximum Range	Sensor-to-Transmitter Matching
RTD	Platinum	0.003850	100	-200 to 850°C -328 to 1562°F	10°C (18°F)	±0.1°C (±0.18°F)	-240 to 960°C -400 to 1760°F	<p>Up to ±0.014°C (±0.025°F) system accuracy*.</p> <p>*High-accuracy measurements are achieved by using a 4-wire, 1000Ω platinum RTD with a span of 100°F (50°F minimum) calibrated in our sensor-matching calibration bath.</p>
			200					
			300					
			400					
			500					
		0.003902	100	-100 to 650°C -148 to 1202°F				
			200					
			400					
			500					
			1000					
0.003916	100	-200 to 510°C -328 to 950°F						
Nickel	0.00672	120	-80 to 320°C -112 to 608°F			-100 to 360°C -148 to 680°F		
Copper	0.00427	9.035	-50 to 250°C -58 to 482°F		±0.85°C (±1.53°F)	-65 to 280°C -85 to 536°F		
Ω	Direct Resistance	n/a	0-4000Ω	0-4000Ω	10Ω	±0.4Ω	0-4000Ω	
	Potentiometer		4000Ω	0-100%	10%	±0.1%	0-100%	
	J	n/a	n/a	-180 to 760°C -292 to 1400°F	35°C 63°F	±0.25°C (±0.45°F)	-210 to 770°C -346 to 1418°F	
	K	n/a	n/a	-150 to 1370°C -238 to 2498°F	40°C 72°F	±0.3°C (±0.54°F)	-270 to 1390°C -454 to 2534°F	
	E	n/a	n/a	-170 to 1000°C -274 to 1832°F	35°C 63°F	±0.2°C (±0.36°F)	-270 to 1013°C -454 to 1855.4°F	
	T	n/a	n/a	-170 to 400°C -274 to 752°F	35°C 63°F	±0.25°C (±0.45°F)	-270 to 407°C -454 to 764.6°F	
	R	n/a	n/a	0 to 1760°C 32 to 3200°F	50°C 90°F	±0.55°C (±0.99°F)	-50 to 1786°C -58 to 3246.8°F	
	S	n/a	n/a	0 to 1760°C 32 to 3200°F	50°C 90°F	±0.55°C (±0.99°F)	-50 to 1786°C -58 to 3246.8°F	
	B	n/a	n/a	400 to 1820°C 752 to 3308°F	75°C 135°F	±0.75°C (±1.35°F)	200 to 1836°C 392 to 3336.8°F	
	N	n/a	n/a	-130 to 1300°C -202 to 2372°F	45°C 81°F	±0.4°C (±0.72°F)	-270 to 1316°C -454 to 2400.8°F	
	C	n/a	n/a	0 to 2300°C 32 to 4172°F	100°C 180°F	±0.8°C (±1.44°F)	0 to 2338°C 32 to 4240.4°F	
Millivolts	DC	n/a	n/a	-50 to 1000mV	4mV	15μV	-50 to 1000mV	

THZ & TDZ

Ordering Information

Unit	Input	Output	Power	Housing
THZ Smart HART Temperature Transmitter	PRG Programmable with standard HART Communicator, HART-based control system, or Moore Industries' PC-based Configuration Software	4-20MA Scaleable to narrower ranges	12-42DC 12-30DC for I.S. applications	DIN DIN-style aluminum housing mounts on 32mm G-type (EN50035) and 35mm Top Hat (EN50022) HPP Hockey-puck housing for mounting in connection heads LH1NS LH1 head with two entry ports: ½-inch NPT conduit and process-black PBT polyester cover LH1MS LH1 head with two entry ports: M20 cable and ½-inch NPT process-black PBT polyester cover LH1CS LH1 head with two entry ports: M20 cable and G½ (BSP) process-black PBT polyester cover LH2NS Explosion-Proof LH2 head with two entry ports: ½-inch NPT conduit and process-black metal cover LH2MS Explosion-Proof LH2 head with two entry ports: M20 cable and ½-inch NPT process-black metal cover CH6 Polypropylene connector head
THZ (DHHousing) Dual-Compartment Smart HART Temperature Transmitter with Display				DH THZ [DH] replacement transmitter with no enclosure DH2NG THZ [DH] enclosed in a 2-Hub, dual-compartment enclosure with two, ½-inch NPT entry ports and a glass cover DH2TG THZ [DH] enclosed in a 2-Hub, dual-compartment enclosure with two, ¾-inch NPT entry ports and a glass cover DH2MG THZ [DH] enclosed in a 2-Hub, dual-compartment enclosure with two, M20 x 1.5 entry ports and a glass cover
TDZ Smart HART Temperature Transmitter with Display				BH2NG 2-Hub, explosion-proof enclosure with two, ½-inch NPT entry ports and a glass cover BH2TG 2-Hub, explosion-proof enclosure with two, ¾-inch NPT entry ports and a glass cover BH2MG 2-Hub, explosion-proof enclosure with two, M20 x 1.5 NPT entry ports and a glass cover BH3NG 3-Hub, explosion-proof enclosure with three, ½-inch NPT entry ports BH3TG 3-Hub, explosion-proof enclosure with two, ¾-inch side-entry NPT ports, one ½-inch bottom port, and a glass cover BH3MG 3-Hub, explosion-proof enclosure with two, M20 x 1.5 side-entry ports, one ½-inch bottom-entry port, and a glass cover D2LC 2-Hub, low base, clear cover, NEMA 4X (IP66) enclosure HP Hockey-puck housing and spring clips DN Snap-in mounting for HP case on TS-32 DIN-rail FL Mounting flanges on HP suitable for relay track or screw mounting FLD Mounting flanges on HP suitable for 3½" relay track mounting <small>P suffix indicates enclosure comes equipped with base and U-bolts for mounting on a 2-inch pipe (i.e. BH2NGP)</small>

To order, specify: Unit / Input / Output / Power [Housing]
 Model Number Example: THZ / PRG / 4-20MA / 12-42DC [DH2NG]

Additional Parts

Every THZ or TDZ order comes with one copy of our Configuration Software on a 3½-inch floppy disk (Windows® 95, 98, and NT 4.0 compatible). The HART RS-232 Modem and the HART Communicator must be purchased separately. However, the THZ and TDZ transmitters work with any standard, third-party communicator, such as the Fisher-Rosemount Model 275.

Additional accessories are available as follows:

Part Number 235-75120-05	Intelligent PC Configuration Software (One copy comes free with each order)
Part Number 803-048-26	HART-to-RS232 Smart Interface Cable with HART Modem

Figure 2. BH Housing Dimensions (For use with the TDZ)

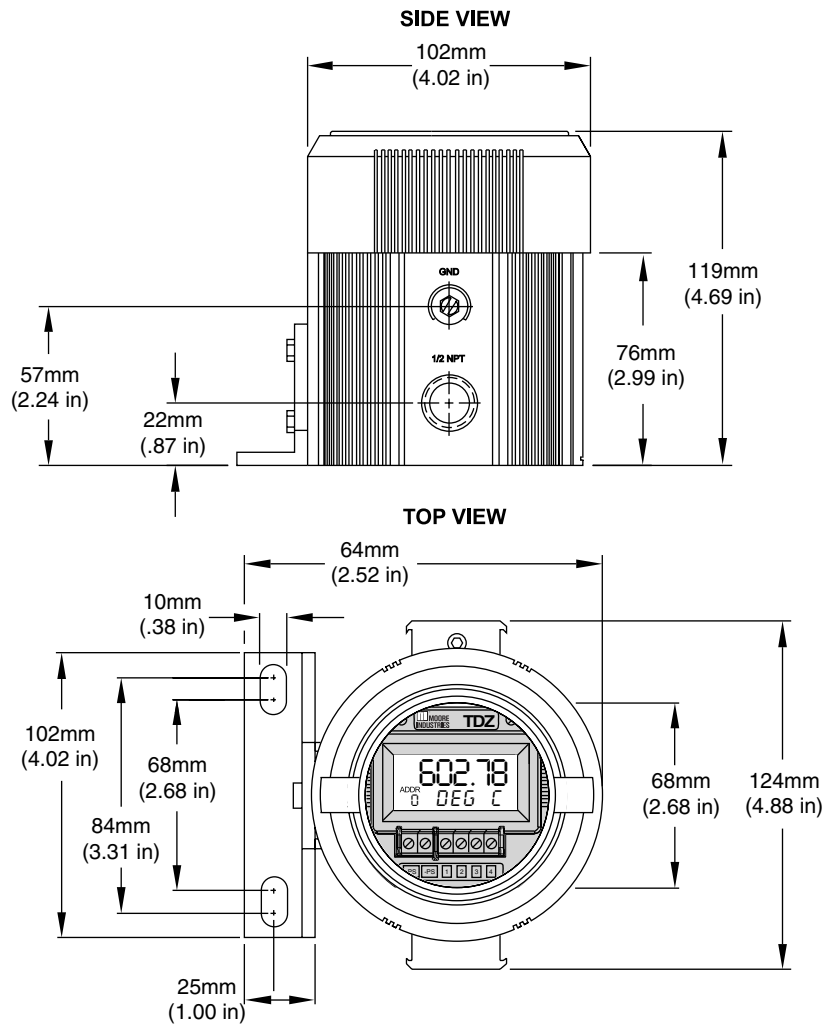

Table 2. THZ [DH] Ambient Effects Table

THZ [DH] Ambient Temperature Effects		
Sensor Type	Digital Accuracy per 1°C (1.8°F) change in Ambient	Analog Accuracy per 1°C (1.8°F) change in Ambient
RTD	0.0015°C	0.001% of span (16mA)
T/C	0.0015°C	0.001% of span (16mA)
Millivolt	0.00025mV	0.001% of span (16mA)
Ohm	0.007Ω	0.001% of span (16mA)

Table 3. THZ [DIN], [HPP], and TDZ Ambient Effects Table

TDZ [HP], THZ [DIN] & THZ [HPP] Ambient Temperature Effects		
Sensor Type	Digital Accuracy per 1°C (1.8°F) change in Ambient	Analog Accuracy per 1°C (1.8°F) change in Ambient
RTD	0.003°C	0.004% of span (16mA)
T/C	0.003°C	0.004% of span (16mA)
Millivolt	0.00025mV	0.004% of span (16mA)
Ohm	0.007Ω	0.004% of span (16mA)

Table 4. Long-Term Stability Specification Table

Stability (% of maximum span)	Input to Output			Input to HART		
	1 year	3 years	5 years	1 year	2 years	5 years
T/C, mV	0.08	0.14	0.18	.008	.014	.019
RTD, Ohm, Potentiometer	0.09	0.16	0.21	.047	.081	0.104

THZ & TDZ

Figure 3. THZ Hockey-Puck (HPP Housing) Dimensions

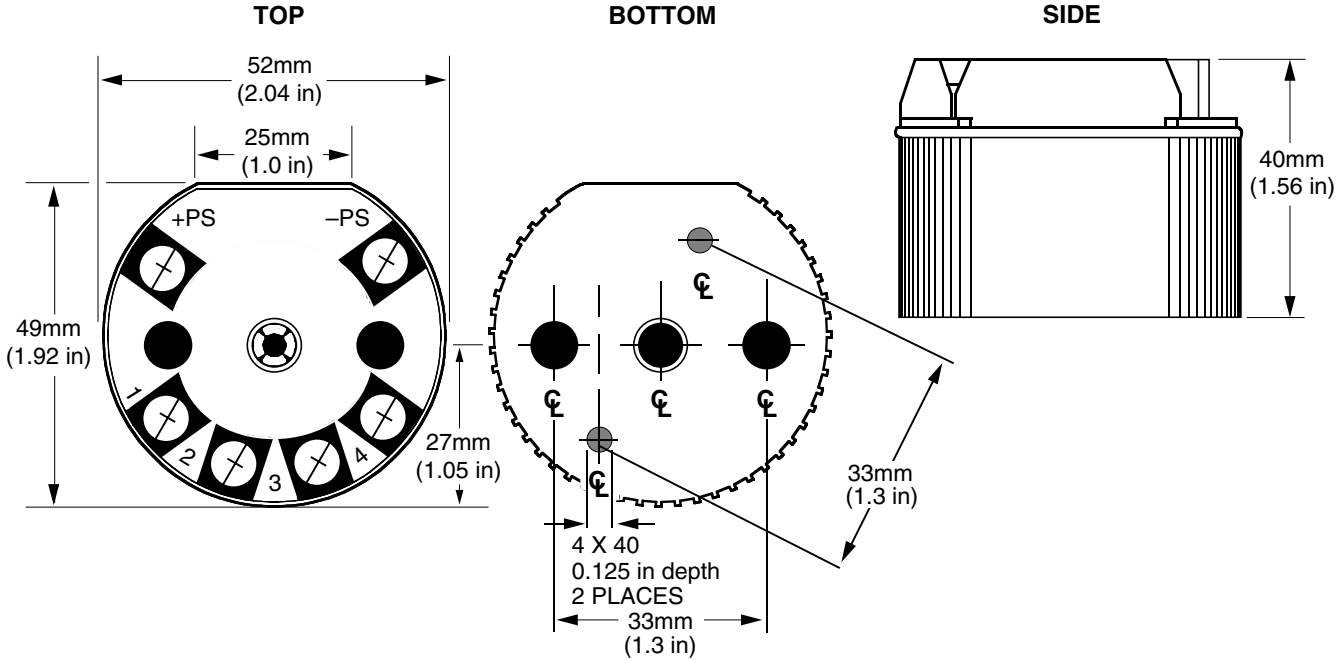

Figure 4. TDZ Hockey-Puck (HP Housing) Dimensions

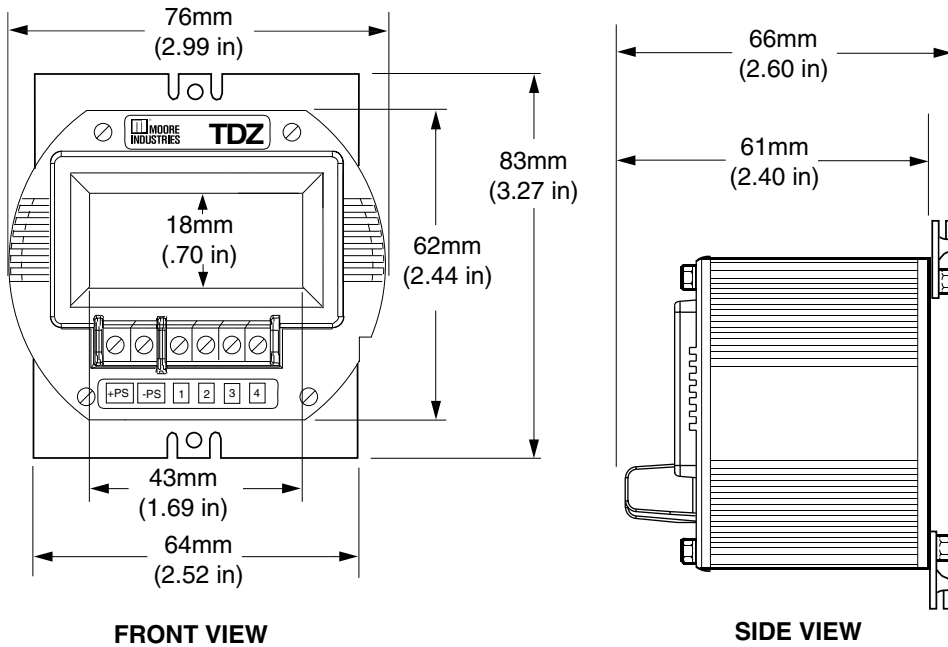

Figure 5. THZ DIN Dimensions

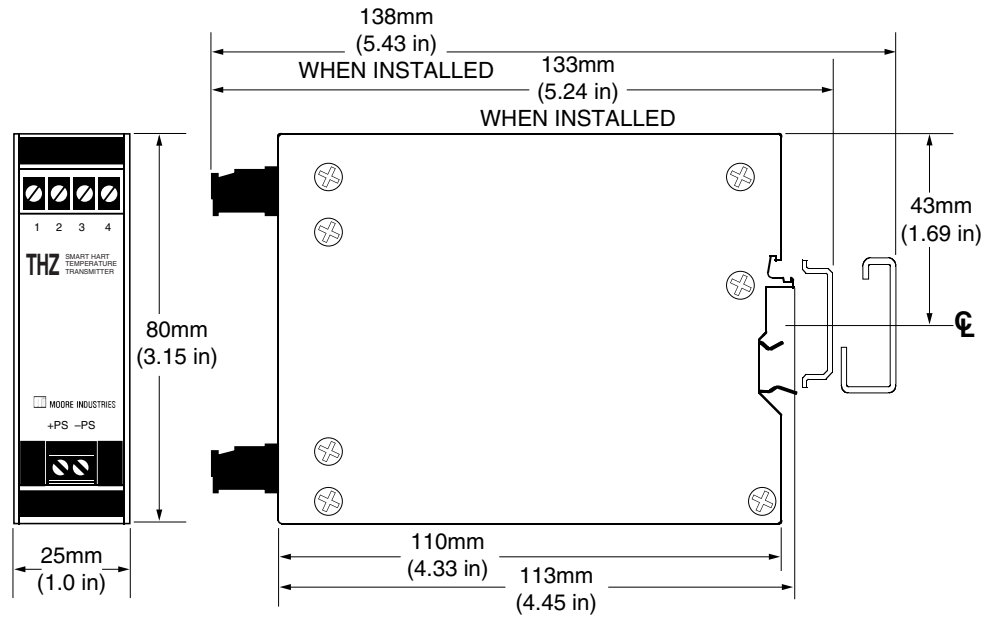
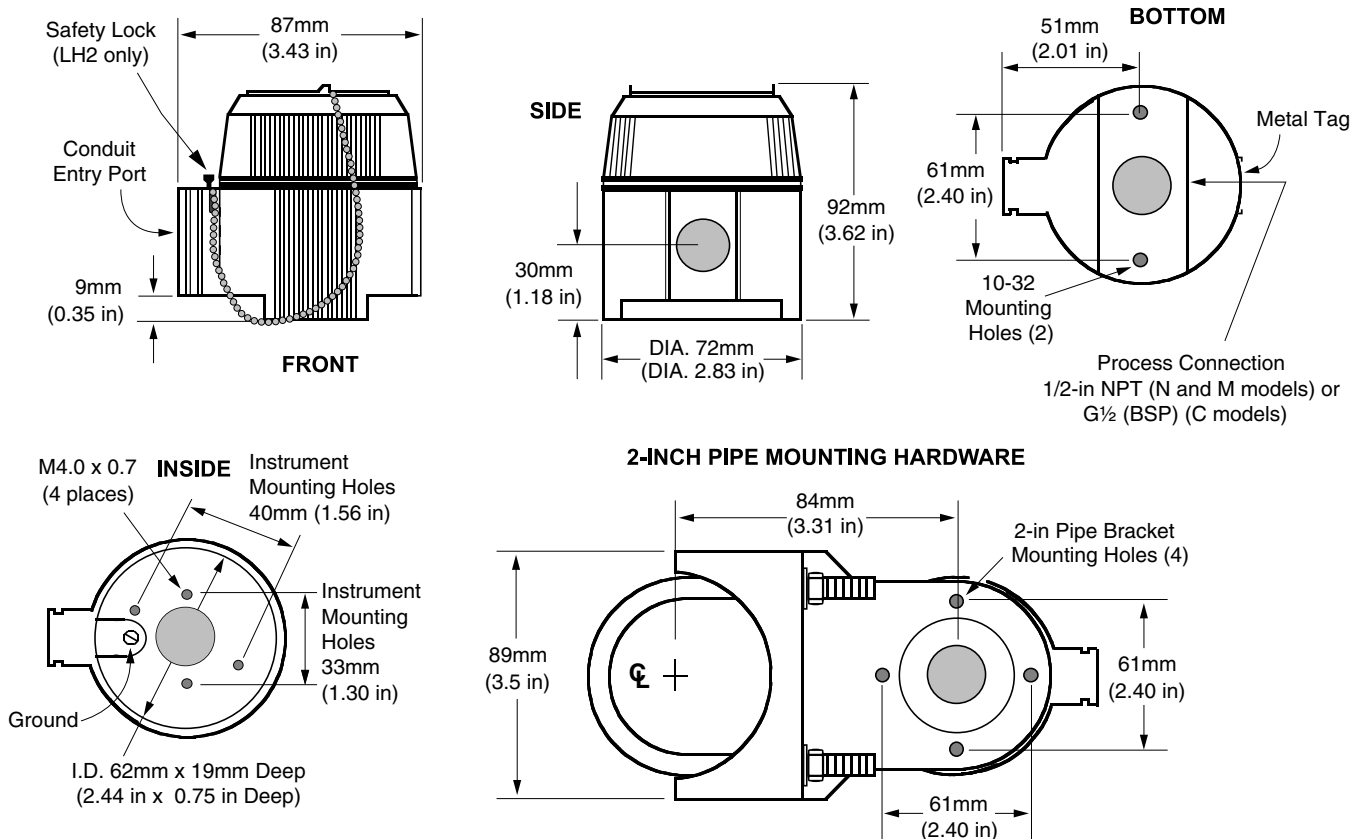

Figure 6. LH Housing Dimensions (For use with the THZ HPP)



THZ & TDZ

Figure 7. THZ Dual Compartment (DH Enclosure) Dimensions.

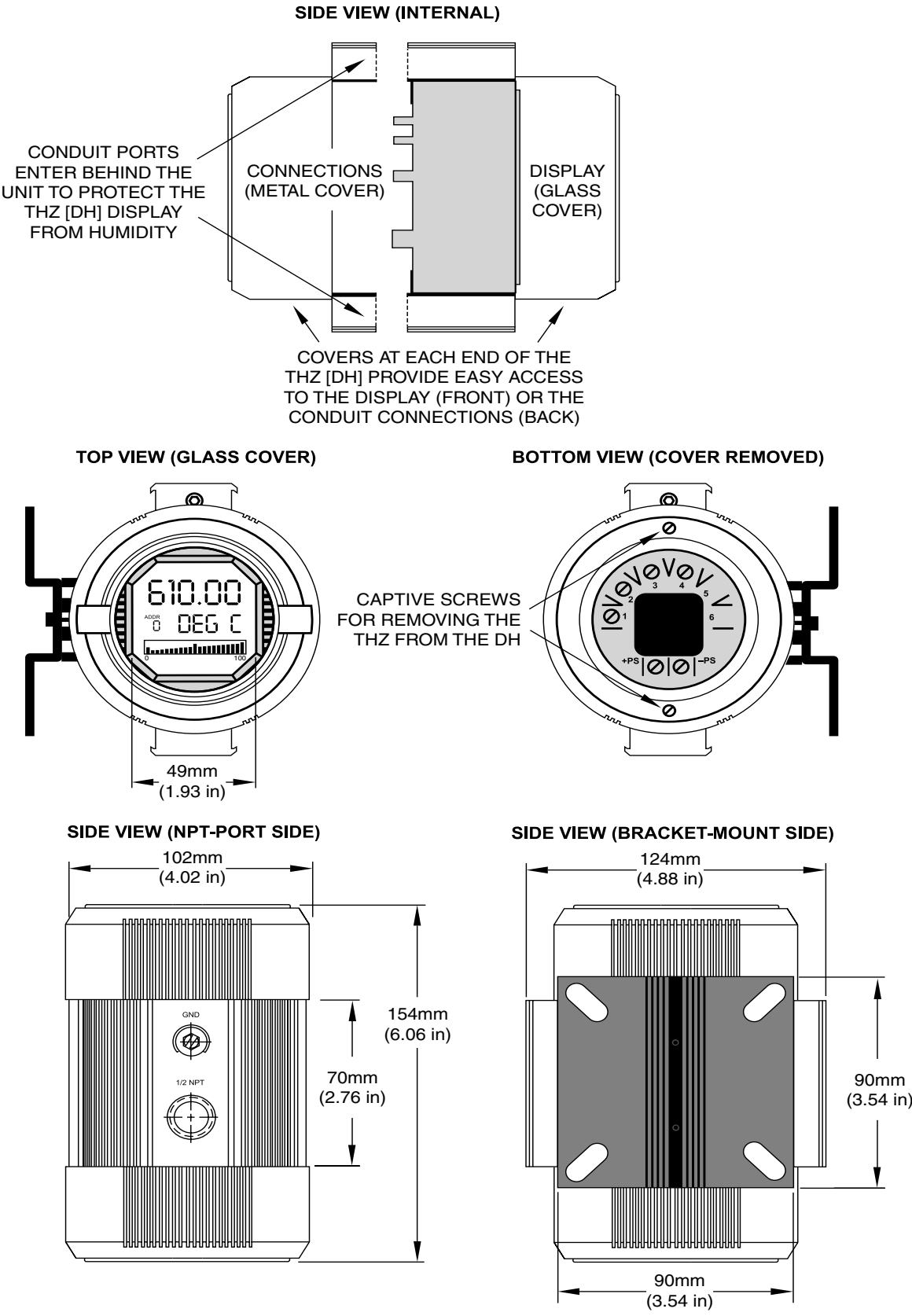
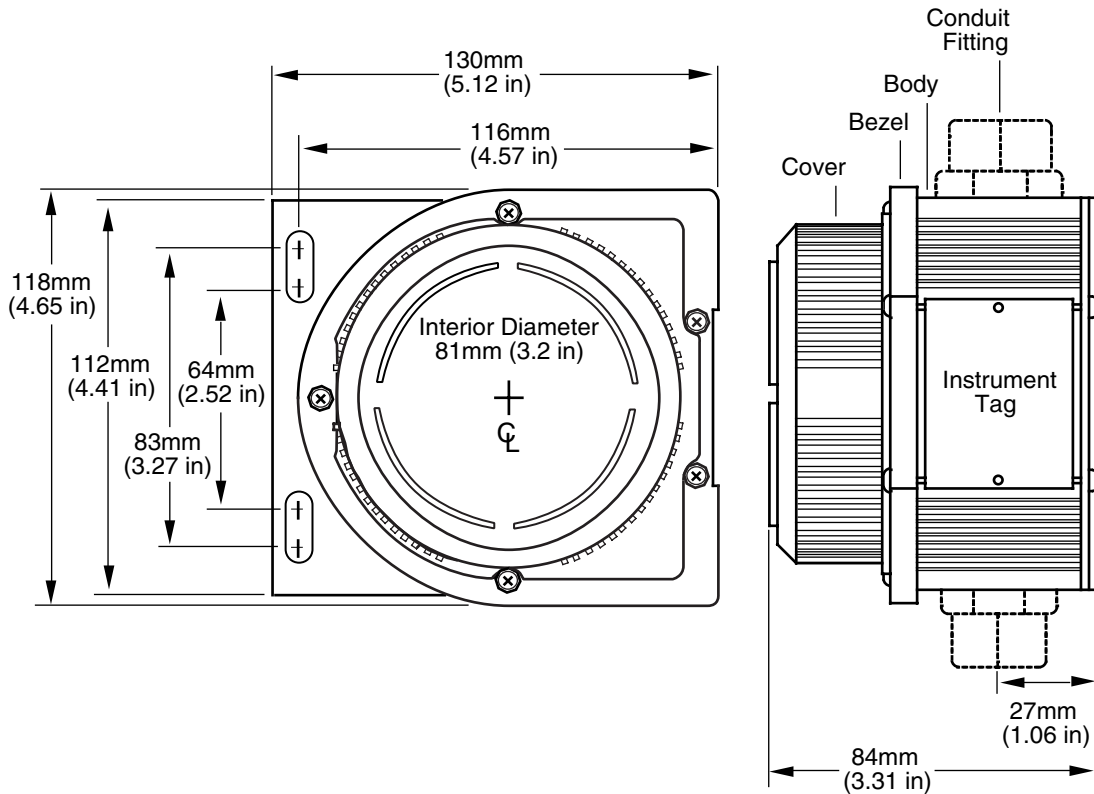

Figure 8. D-BOX Housing Dimensions (For use with the TDZ)



Configuring a THZ or TDZ

One of the benefits of these transmitters is that there are no internal or external controls to adjust or settings to change. All operating parameters are set using either a HART Communicator or a PC and Moore Industries' Intelligent PC Configuration software.

The software settings are "downloaded" to the transmitter in the form of a Configuration File and stored in the instruments' memory. You can save a backup copy of the file on your PC hard drive or disk. The transmitter communicates with the PC through a HART modem connection to the PC's serial port.

You can configure the THZ or TDZ with either a standard HART Communicator or our PC software. Figure 10 and Table 5 provide the information you need to configure your unit.

Using a PC...

If you are going to use a PC to configure your unit, first install the software as described on the next page, then setup the hardware as shown in Figure 10. Use our comprehensive HelpMap Navigation System in the PC Configuration Program for further instructions on setting up your THZ or TDZ.

Note:

To use the HelpMap Navigation System, click on the  button *OR* click on *HELP*, then *HelpMap* on the command bar to start this advanced help tool.

THZ & TDZ

Installing the Configuration Software

Refer to Table 5 for the equipment needed.

1. Insert the diskette labeled “TDZ/THZ Configuration Program Installation Disk 1 of 3” into the floppy drive of the PC.
2. In Windows® 95/98/NT, go to the “Start” menu, and access “Settings”, then “Control Panel”, and finally “Add/Remove Programs”.
3. Click “Install” and follow the instructions on the screen.

Note:

Two utility disks are also provided with your PC Program. These are for users of Windows 95 with Internet Explorer 3.0x, or Windows NT. Do not install these if you are using Windows 98.

Once the Configuration Program is installed on the PC, the THZ or TDZ can be connected to equipment to simulate input and monitor output. The user can then change the transmitter’s operating parameters.

No Transmitter Needed

It is not necessary to connect the transmitter to a PC to create configuration files using the software. The Configuration Program can be run without connecting a transmitter, and **most** parameters can be set without benefit of input from a sensor or transmitter.

This makes it easy to create a set of operating parameters, save them to disk, and download them to one or more transmitters at a later time.

The THZ or TDZ **must** be connected to the PC in order to: trim input, trim output, assign a tag, perform a loop test, receive (via download) a configuration file, and save the configuration file from the transmitter’s memory.

Connecting the THZ or TDZ to the PC

To set any of the options, you must first connect the unit to the PC. The THZ hockey-puck, THZ DIN, THZ DH, and TDZ all have the same terminal designations, and all can be setup using the connections shown in Figure 10, page 12.

Establish a simple current loop for the transmitter by connecting a 24-volt power supply, a 250Ω resistor, and the transmitter in series. See Table 5 below for information on the necessary equipment.

Then connect a suitable HART modem. Connect the RS-232 end of the modem to the PC’s COM port, then connect the HART output end of the modem (two hookup wires) across the transmitter or the load resistor.

Table 5. Assembling the equipment needed to configure the THZ or TDZ

Device	Specifications
Variable Input Simulator for Thermocouple, RTD, Millivolt, Potentiometer, or Decade Resistance Box	Variable; Accurate to ±0.05% of unit span
Power Supply	24Vdc, ±10%
Precision Load Resistor	250 ohms, ±0.01% HART specifies that total loop resistance is to be maintained between 250 ohms and 1100 ohms.
Multimeter (optional)	Accurate to ±0.025% of span; e.g., Fluke Model 87
Personal Computer (Required only if using a PC for setup)	80386-based(or faster) IBM PC, or 100% compatible; 1.44MB floppy diskette drive 4Mb free RAM; 8Mb recommended; 20Mb free disk space on hard drive (More RAM & hard disk space is required for Windows 98 or NT) Microsoft Windows® 95, 98, or NT Internet Explorer 3.0+ (required for HelpMap) 1 (one) serial port (COM 1, 2, 3, or 4) set to 4800 baud, no parity, 8 data bits, and 1 stop bit
HART Modem Cable (Required only if using a PC)	Moore Industries part number 803-048-26 , or equivalent
Moore Industries PC Configuration Software (Required only if using a PC)	Version 1.0 or greater, successfully installed to the hard drive
HART Communicator (Required only if NOT using a PC)	Fisher-Rosemount Model 275 or equivalent

Figure 9. Most of the THZ or TDZ Operating Parameters can be set from the Main Screen of the Configuration Program.

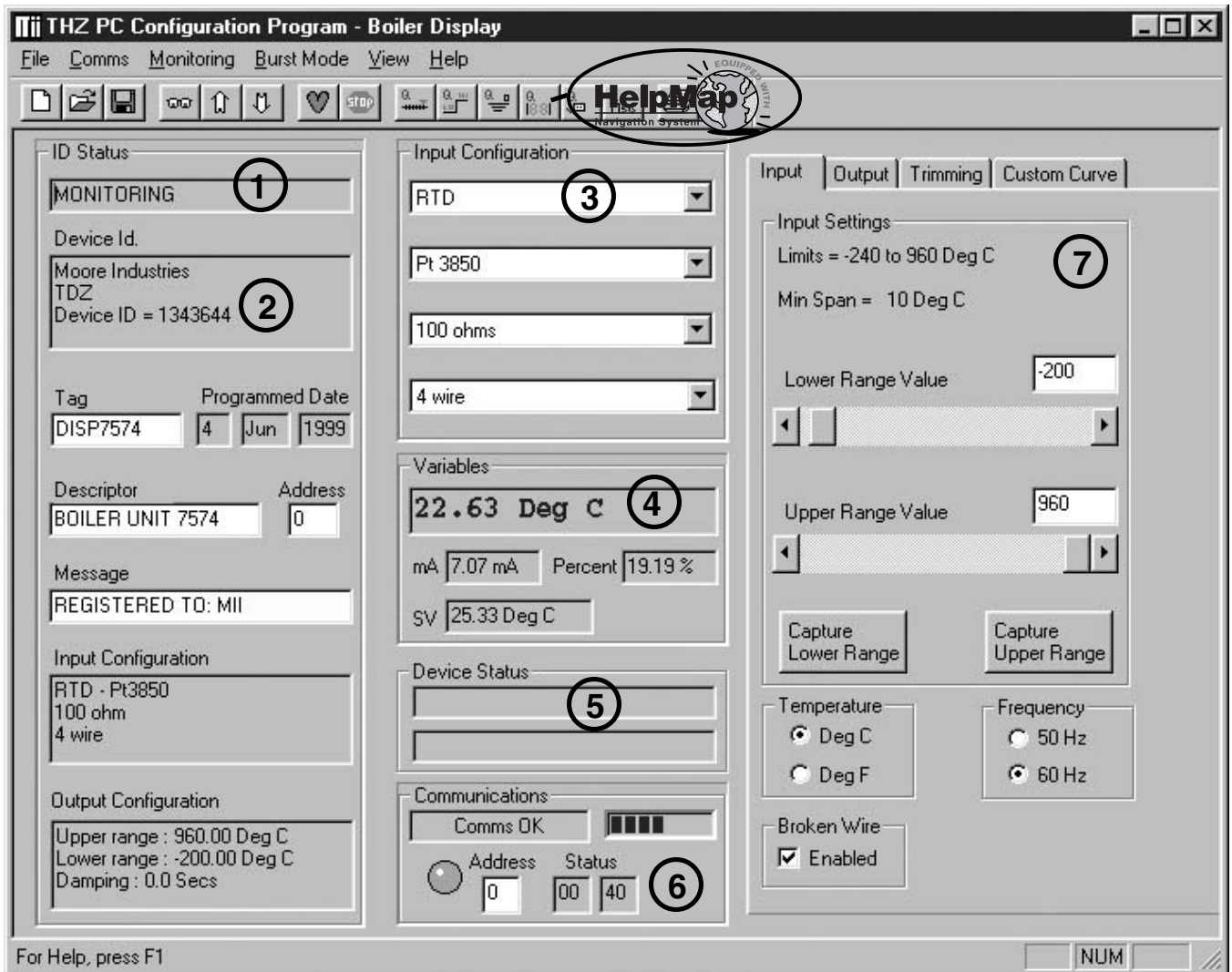

Using the PC Program

Once the default configuration has been saved to disk, it is safe to program the other parameters. For detailed information on how to use our configuration software, access our HelpMap Navigation System. The PC Software is made up of these sections:

1. **ID Status**—This portion of the screen displays the activity of the connected unit. It will show you if the unit is *Idle*, *Uploading*, *Downloading*, *Monitoring*, or *Searching*.
2. **Device Information**—The *Device ID*, *Tag*, *Programmed Date*, *Descriptor*, *Address*, *Message*, and *Device Configuration* all display properties of the transmitter.
3. **Input Configuration**—Use this section to select and configure the sensor type. Choose from *Thermocouple*, *RTD*, *Millivolt*, *Resistance*, or *Potentiometer*.
4. **Variables**—Watch this section to track all the information that your transmitter is monitoring.
5. **Device Status**—Displays the status of the PC's communication with the transmitter. Any malfunction reported by the transmitter will be displayed here.
6. **Communications**—Shows the status of communications between the THZ or TDZ and the master. The green flashing light verifies that the transmitter is communicating successfully with the PC.
7. **Input/Output/Trimming/Custom Curve Tab**—This set of tabs allows you to select specific functions for the PC software, then download it to the transmitter.

HelpMap Navigation System—For detailed information on any THZ- or TDZ-related topic, access the HelpMap Navigation System by clicking on the questionmark button.

THZ & TDZ

Figure 10. Using a HART Communicator or the PC to configure the THZ or TDZ.

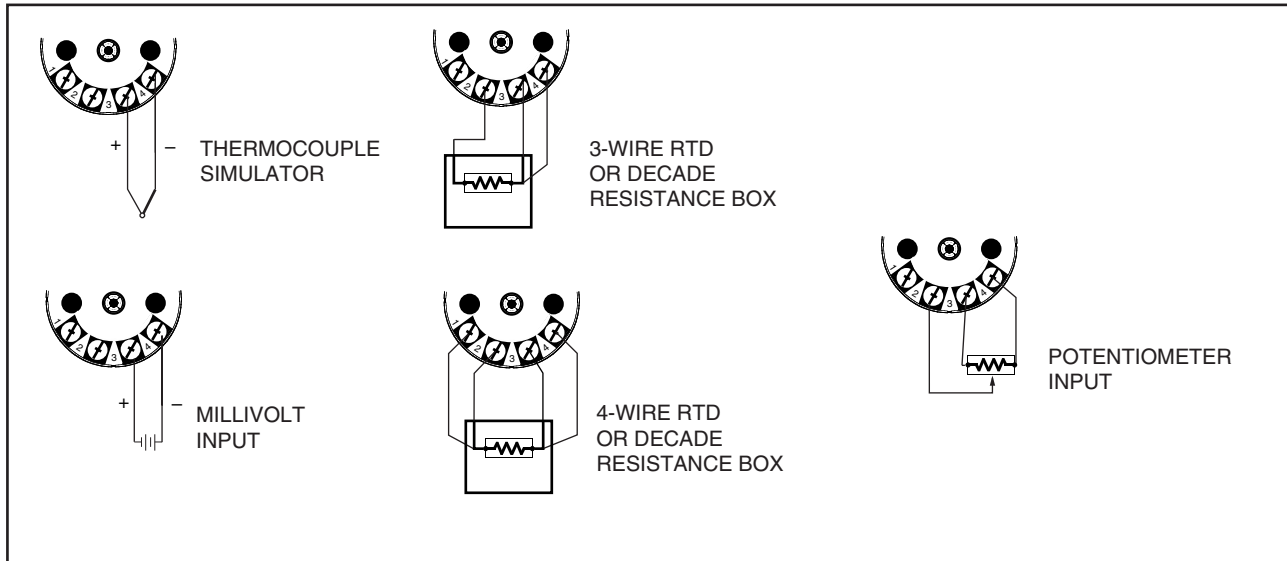
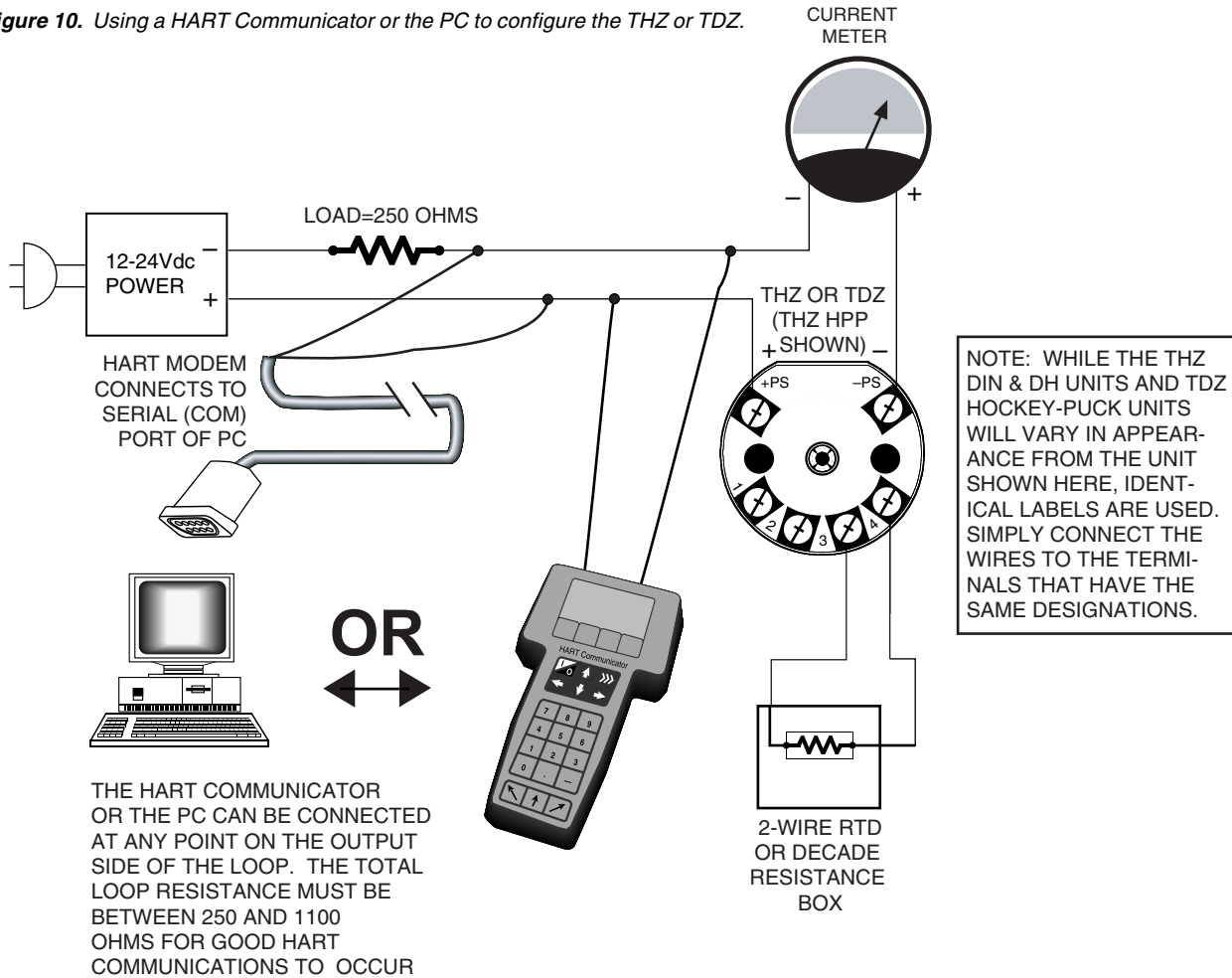

Using the HART Communicator

The THZ and TDZ can be programmed using a HART Communicator. If your communicator is equipped with the Device Description (DD) for your transmitter, the following section, “The HART Communicator Menu with a Device Description”, gives an overview of the menus and instructions for programming.

The THZ and TDZ DD is available on the HART Foundation’s Device Driver Library Release October 1999 and later. To determine if your communicator has the appropriate Device Description, press “1” to select “Offline” and press “1” again to select “New Configuration”. A list of companies will appear which will include Moore Industries if you have the appropriate Device Description.

If your communicator is *not* equipped with the Device Description that you need, go to “The HART Communicator Menu without a Device Description” on page 17. Some capabilities can only be accessed if your communicator is equipped with a Device Description. Moore Industries can factory-configure parameters that are not accessible through the generic DD.

Moore Industries can update your HART Communicator with all of the latest, approved HART Device Descriptions, including the DD for the THZ or TDZ. Just send your communicator to our Interface Solution Center headquarters in Sepulveda, California with our configuration sheet indicating the DD’s you need. We’ll load the Device Descriptions of your choice for a nominal charge.

Programming when a Device Description is Available

With the transmitter connected as illustrated in Figure 10, apply power and turn the communicator on. After a brief self-test, the communicator will show the main menu and identify the unit as a THZ or TDZ.

This section contains the instructions for programming the transmitter using a HART Communicator that has been programmed with a HART Device Description (See pages 14 & 15). If your communicator doesn’t have the appropriate Device Description, skip to “The HART Communicator Menu without a Device Description” on pages 16 & 17.

Figure 11 on the next page shows an overview of the programming menus for the configuration process. This figure will be used frequently.

THZ & TDZ

Figure 11. Summarizing the THZ and TDZ Configuration Menus in a HART Communicator

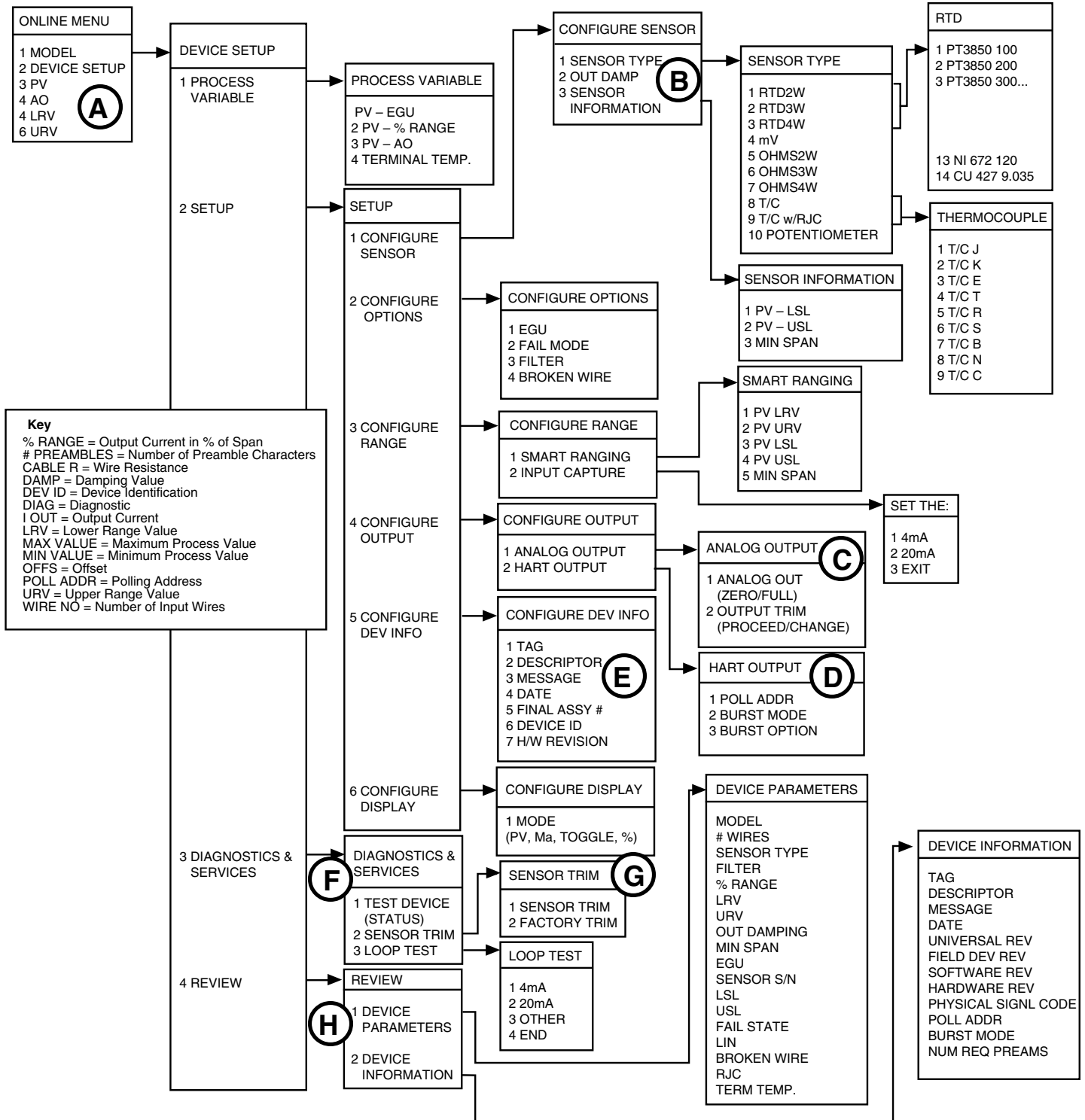

The HART Communicator Menu With a Device Description

A. Displaying the Current Process Value

The ONLINE MENU displays the current process value (i.e. °C in a temperature application), the lower and upper range values, and the actual output current. Use the DEVICE SETUP menu to configure the THZ or TDZ.

B. Configuring the Transmitter's Input

In the "Configure Sensor" Menu, you can program the type of sensor being used, the sensor's upper and lower range values, damping time, and the number of input wires.

Damping smooths input fluctuations by taking an average over a user-programmed time period, and using this value for the THZ or TDZ output. The damping time can be set between 0 and 30 seconds.

C. Configuring the Analog Output

In the "Analog Output" menu, you can enter the output range values and perform output trimming.

D. Configuring the HART Output

In the "HART Output" menu, you can enter a polling address between 0 and 15 for an individual THZ or TDZ, turn burst mode on/off, and change options.

Note:

If the polling address is set to 0, the transmitter is automatically set to analog mode. Multiple units on the same bus must have different addresses.

E. Configuring the Device Information

In the "Configure Dev Info" menu, you can enter a tag (8 characters), date, descriptor (i.e. a location code of up to 16 characters), a message (32 characters), and final assembly numbers for the transmitter. You cannot change the device ID or the Hardware Revision in the field.

F. Changing Loop Current to a Fixed Value

The "Diagnostics & Services" menu allows you to change the loop current to a fixed output. Once the transmitter's output current is set to a known value, it can be checked against the value being received by your receiving device.

Note:

The THZ or TDZ must be removed from automatic control in order to run the Loop Test.

G. Trimming the Input Sensor

From the "Sensor Trim" menu, you can enter the offset for a non-calibrated sensor or reset the unit to the factory settings. A feature new to the THZ is the ability to trim one or two points along any portion of the range, not just zero or full span.

Offset for non-calibrated sensors can be entered two different ways. SENSOR TRIM is used to enter the offset because it allows the unit to synchronize with the input. This command can only be used in a controlled environment because fluctuating input makes it difficult for the unit to synchronize with the input.

Note:

Once the factory trim process is complete, all other trim values are erased. Reset takes 5 seconds. Pushing Abort during this time stops the process.

H. Checking on Your Transmitter's Settings

Use the "Review" menu to check on the transmitters' settings without the danger of inadvertently changing any of them.

THZ & TDZ

Figure 12. Generic Menu Overview

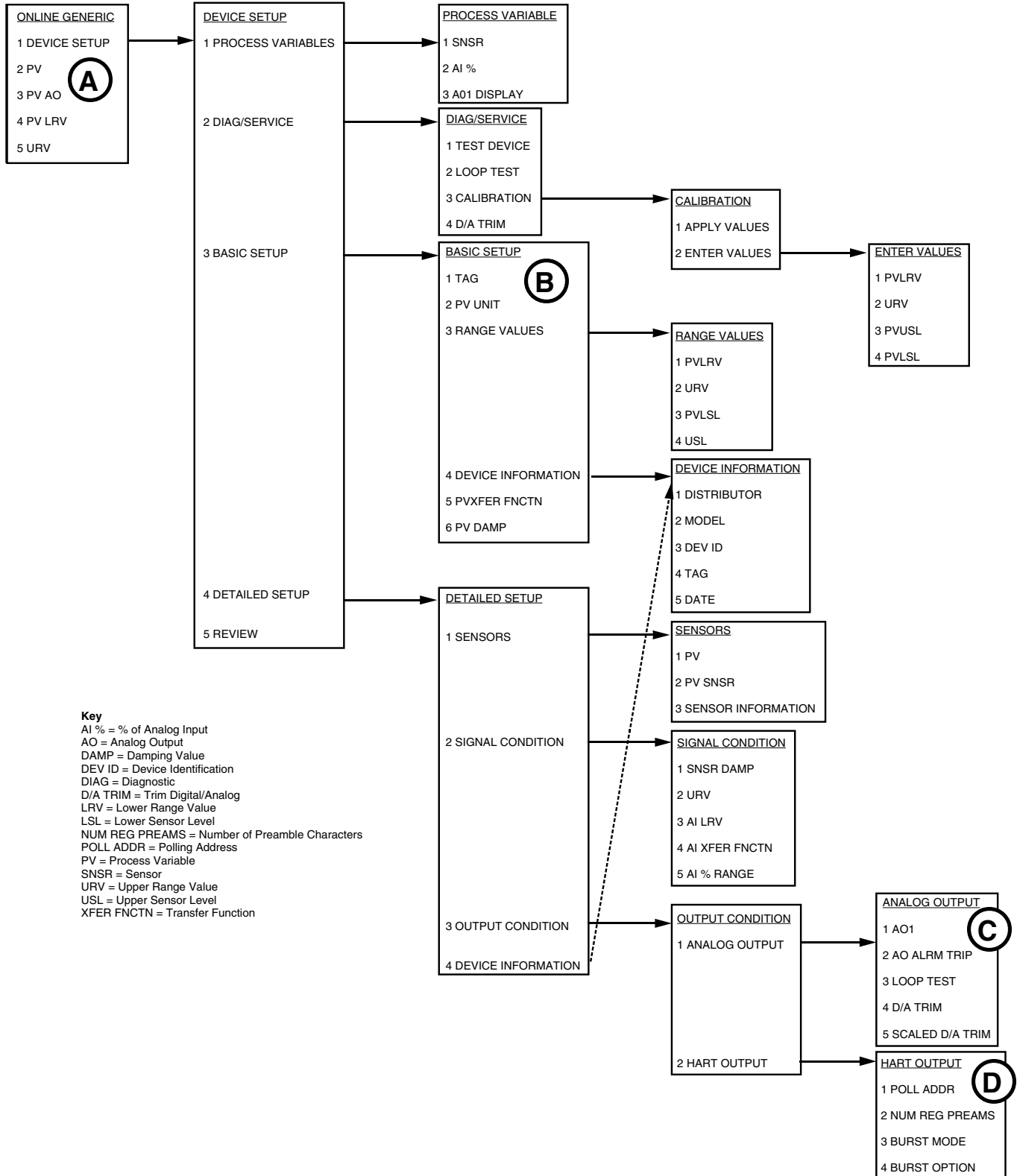

The HART Communicator Menu Without a Device Description

This section contains the instructions for programming a THZ or TDZ using a HART communicator without a Device Description. If your communicator has a Device Description, please see “The HART Communicator Menu with a Device Description” on page 15.

A. Displaying the Current Process Values

The initial screen, the “Online Generic” menu, displays the process value, analog output, and the programmed upper and lower parameters of the process value. The generic overview menu (Figure 12 on page 16) shows the screen. Use the DEVICE SETUP menu for configuring your THZ or TDZ.

B. Configuring THZ or TDZ Input

The “Basic Setup” menu allows you to enter a name for an individual transmitter, the units of measurement, the upper and lower range and sensor values, and a damping time between 0 and 30 seconds.

Damping smooths input fluctuations by taking an average over a user-programmed time period and using this value for the output.

C. Configuring THZ Analog Output

The “Analog Output” menu displays the analog output, changes the loop current to a fixed value so that it can be checked against the value being received and displayed by your receiving device, and enters and trims the sensor.

D. Configuring HART Output

From the “HART Output” menu, you can enter the polling address and display the number of preamble characters sent by the master to the slave to ensure synchronization.

If the polling address is set to 0, the THZ or TDZ is automatically set to analog mode. Multiple units on the same bus **must** have different addresses.

THZ & TDZ

Installation

Installation consists of physically mounting the unit and completing the electrical connections.

Mounting the THZ or TDZ

The hockey-puck THZ fits inside a 30-35mm connection head (such as the LH1) using captive mounting screws. The DIN THZ can be mounted on standard DIN mounting rails. The dual-compartment [DH] THZ installs into the [DH] enclosure and can be mounted to a wall or 2-inch pipe. The hockey-puck TDZ can be mounted with rails, flanges, or in one of our larger housings, such as the D-BOX or BH.

Making the Electrical Connections

The connections for the various inputs are shown in Figure 10 on page 12. The figure shows a single transmitter. If you are using multiple units, connect them using the connections shown in Figure 13.

In multi-drop networks, the unit's receiving device is normally a HART-communicating control system acting as the HART Primary Master. The control system uses each transmitters' individual address to access real-time process data, sensor diagnostics, and THZ diagnostic data. The address is also used to locate the appropriate THZ or TDZ, to initiate configuration, and to calibrate. A HART communicator, acting as the HART Secondary Master, can be used to simultaneously access information from, or transmit configuration information to the transmitter from anywhere along the HART digital link.

Make sure that the total loop resistance is at least 250Ω so that the 4-20mA signal containing the HART protocol is not shorted. If loop resistance is less than 250Ω, add a resistor.

Recommended Ground Wiring Practices

Moore Industries recommends the following ground wiring practices:

- Any Moore Industries product in a metal case or housing should be grounded.
- The protective earth conductor must be connected to a system safety earth ground before making any other connections.
- All input signals to, and output signals from, Moore Industries' products should be wired using a shielded, twisted pair technique. Shields are to be connected to an earth or safety ground at the unit itself.
- The maximum length of unshielded input and/or output signal wiring should be two inches.

CE Conformity

Installation of any Moore Industries' products that carry the CE certification **must** adhere to the guidelines above in order to meet the requirements set forth in applicable EMC directives (EN55011, EN 50082-1, EN50082-2, etc.) Consult the factory for the most current information on products that have been CE certified.

Figure 13. Connecting the THZ or TDZ in Multi-Drop Configuration

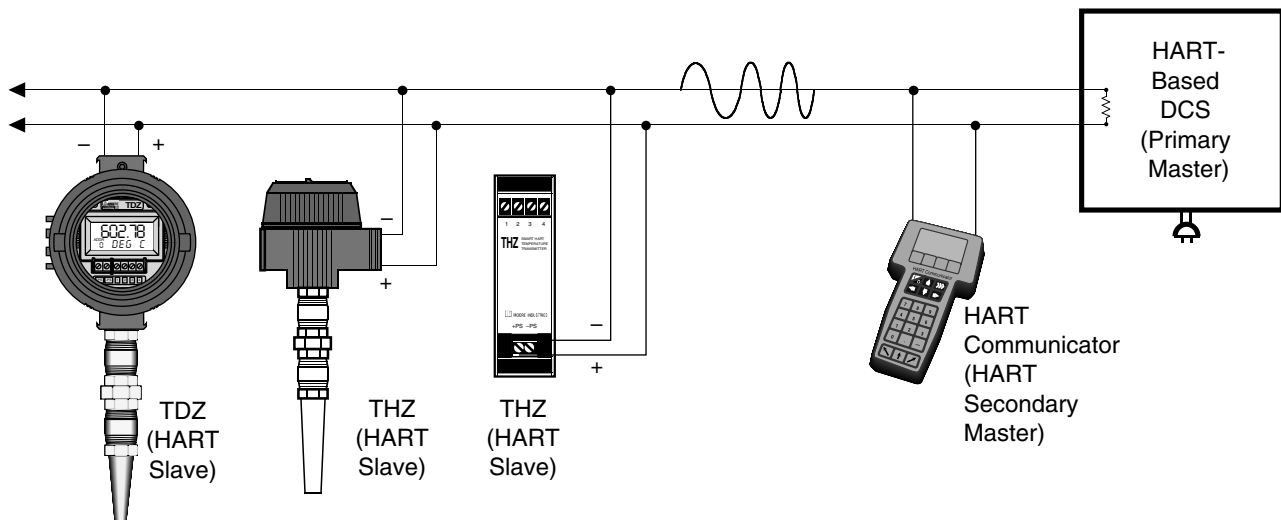

Operation

Once programmed, calibrated, installed, and supplied with the correct power, THZ and TDZ transmitters begin to operate immediately. Depending upon environmental conditions, they can be expected to operate unattended for extended periods of time.

HART Protocol

This section of the manual gives an overview of the HART format used by THZ and TDZ modules during operation. Use the information in this section to process the data provided by the module(s) during operation. For more information on the HART protocol, contact the HART Foundation at:

The HART Communication Foundation
9390 Research Blvd, Suite 1-350
Austin, TX 78759-6540 U.S.A.
(512) 794-0369
www.ccsi.com/hart

Device Types

To implement two-way communication between the THZ and the device being used to configure it or receive its information, the THZ or TDZ operates in a HART Master/Slave structure. The THZ or TDZ is the Slave (or slaves in a multidrop network).

There can be two Masters per system: a Primary Master and a Secondary Master. Masters are typically either a HART Hand-Held Communicator or a HART-based control system.

In many applications, the Primary Master is a HART Hand-Held Communicator. The communicator is used solely as a configuration tool to set up the transmitter, periodically view its real-time process measurement, or view its operating and diagnostic information from a loop termination point.

Digital Signal

One of the advantages of the HART protocol is that the digital information is conveyed by the same wires used to output the 4-20mA signal. After being polled by the master, the THZ or TDZ responds to the inquiry by modulating the 4-20mA current 0.5 mA above or below the output signal. 1200 Hz represents 1 and 2200 Hz represents 0.

Communication Speed and Format

The speed of the HART transmission is 1200 baud. The time delay between a master initiating a request for data from a slave and the slave receiving and acknowledging the request depends upon which command is issued. Generally, a master can poll a slave 2-3 times per second.

The byte structure of the HART signal is:

1 Start Bit, 8 Data Bits, 1 Odd Parity Bit, 1 Stop Bit.

Maintenance

Moore Industries suggests a quick check for terminal tightness and general unit condition every 6-8 months. Always adhere to any site requirements for programmed maintenance.

Customer Support

Moore Industries is recognized as the industry leader in delivering top quality to its customers in products and services. We perform a battery of stringent quality assurance checks on every unit we ship. If any Moore Industries product fails to perform up to rated specifications, call us for help. Our highly skilled staff of trained technicians and engineers pride themselves on their ability to provide timely, accurate, and practical answers to your process instrumentation questions.

Factory phone numbers are listed on the back cover of this manual.

If problems involve a particular THZ or TDZ, there are several pieces of information that can be gathered **before you call the factory** that will help our staff get the answers you need **in the shortest time possible**. For the fastest service, gather the complete model and serial number(s) of the problem unit(s) and the job number of the original sale.

Troubleshooting the PC Software

With the large variety of PC manufacturers that exist today, there is always the small chance that a particular PC will not work with a particular piece of software.

We have provided quick fixes in case you have any compatibility problems with the HelpMap Navigation System.

When I try to run the HelpMap software, it gives me an error that says the HHCtrl.ocx is either old or needs to be updated. What can I do?

You are probably running Internet Explorer 3.0 or earlier.

First, verify that you have a copy of Internet Explorer, then check the version by going to the “Help” and “About Internet Explorer” menu in Internet Explorer program. If you have an older version, you can download a newer version of Internet Explorer from the Microsoft website (www.microsoft.com), or you can update your existing software by following the directions below.

We provide two utility disks (labeled *Utility Disk 1* and *Utility Disk 2*) that will update your Internet Explorer so that it can run HelpMap. To install these disks, follow the directions on their labels.

Installing the programs on these two disks should update your Internet Explorer software so that you can access the HelpMap Navigation System.

Appendix A: Intrinsic Safety

This appendix contains the installation diagram for the THZ & TDZ carrying the intrinsically safe option. It also includes guidelines for setting up zener barriers necessary in these types of applications.

These diagrams must be used to augment the installation instructions earlier in this manual for units that are to operate in areas requiring intrinsically safe instrumentation.

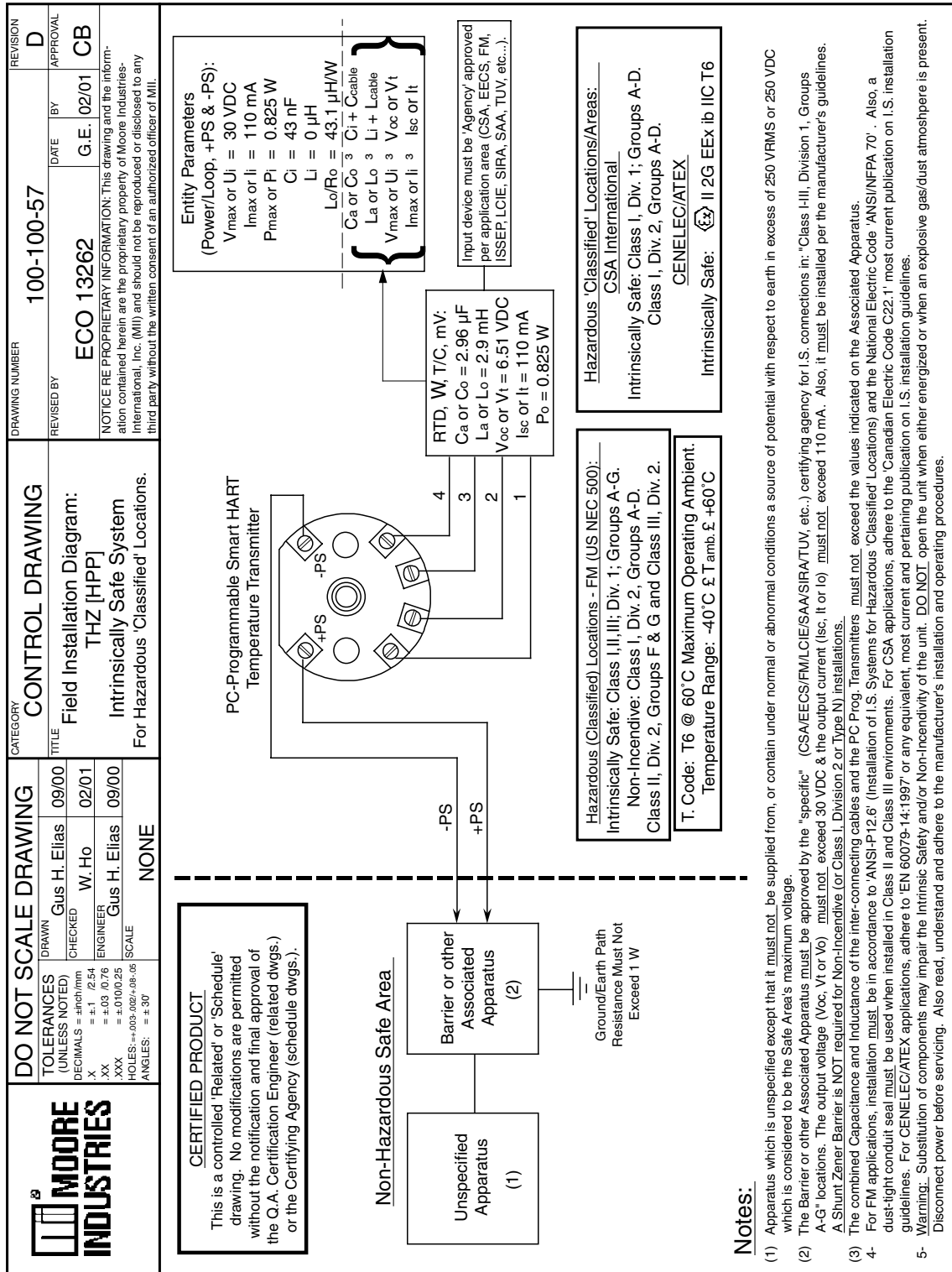

	DO NOT SCALE DRAWING	CONTROL DRAWING	DRAWING NUMBER 100-100-56	REVISION C
	DRAWN: Gus H. Elias 09/00 CHECKED: W. Ho 02/01 ENGINEER: Gus H. Elias 09/00 SCALE: NONE	TITLE Field Installation Diagram: TDZ [HP] Intrinsically Safe System For Hazardous 'Classified' Locations	REVISED BY: ECO 13262 DATE: 02/01 G.E. CB	
TOLERANCES (UNLESS NOTED) DECIMALS = \pm .001 / .0025 FRACTIONS = \pm .001 / .0025 HOLES: \pm .003 / .0025 / .005 ANGLES: \pm 30'				
NOTICE RE PROPRIETARY INFORMATION: This drawing and the information contained herein are the proprietary property of Moore Industries International, Inc. (MI) and should not be reproduced or disclosed to any third party without the written consent of an authorized officer of MI.				

CERTIFIED PRODUCT

This is a controlled 'Related' or 'Schedule' drawing. No modifications are permitted without the notification and final approval of the Q.A. Certification Engineer (related dwgs.) or the Certifying Agency (schedule dwgs.).

PC-Programmable Smart HART Temperature Transmitter with Display.

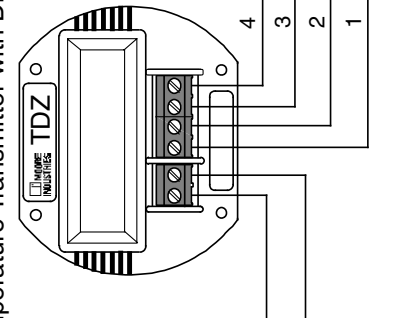

Non-Hazardous Safe Area

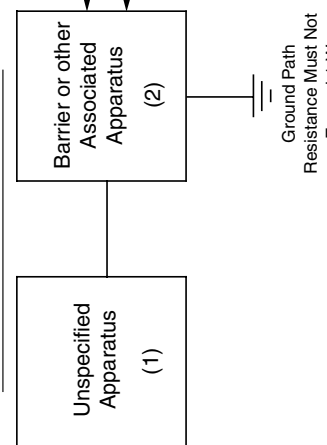

Entity Parameters (Power/Loop, +PS & -PS):

V_{max} or $U_i = 30$ VDC
 I_{max} or $I_i = 110$ mA
 P_{max} or $P_i = 0.825$ W
 $C_i = 18.5$ nF
 $L_i = 0$ μ H

C_a or C_o \leq C_{cable}
 L_a or L_o \leq L_{cable}
 V_{max} or U_i \leq V_{oc} or V_t
 I_{max} or I_i \leq I_{sc} or I_t

Input device must be 'Agency' approved per application area (CSA, EECs, FM, ISSEP, LCIE, SIRA, SAA, TUV, etc...).

RTD, W, T/C, mV:

C_a or $C_o = 2.96$ μ F
 L_a or $L_o = 2.9$ mH
 V_{oc} or $V_t = 6.51$ VDC
 I_{sc} or $I_t = 110$ mA
 $P_o = 0.825$ W

Hazardous 'Classified' Locations/Areas:

CSA International

Intrinsically Safe: Class I, Div. 1; Groups A-D.
Class I, Div. 2, Groups A-D.

GENELEC/ATEX

Intrinsically Safe:  II 2G EEx ib IIC T4

Hazardous 'Classified' Locations - FM (US NEC 500):

Intrinsically Safe: Class I, II, III; Div. 1; Groups A-G.
Non-Incendive: Class I, Div. 2, Groups A-D.
Class II, Div. 2, Groups F & G and Class III, Div. 2.

T-Code: T4A @ 40°C & T4 @ 60°C
Maximum Operating Ambient Temperature.
Ambient Range: -40°C \leq T amb. \leq +60°C

Notes:

- (1) Apparatus which is unspecified except that it must not be supplied from, or contain under normal or abnormal conditions a source of potential with respect to earth in excess of 250 VRMS or 250 VDC which is considered to be the Safe Area's maximum voltage.
- (2) The Barrier or other Associated Apparatus must be approved by the "specific" (CSA/IECS/FM/LCIE/SAA/SIRA/TUV, etc.) certifying agency for I.S. connections in: "Class I-III, Division 1, Groups A-G" locations. The output voltage (V_{oc} , V_t or V_o) must not exceed 30 VDC & the output current (I_{sc} , I_t or I_o) must not exceed 110 mA. Also, it must be installed per the manufacturer's guidelines.
- (3) A Shunt Zener Barrier is NOT required for Non-Incendive (or Class I, Division 2 or Type N) installations.
- 4- For FM applications, installation must be in accordance to 'ANSI-P12.6' (Installation of I.S. Systems for Hazardous 'Classified' Locations) and the National Electric Code 'ANSI/NFPA 70'. Also, a dust-tight conduit seal must be used when installed in Class II and Class III environments. For CSA applications, adhere to the 'Canadian Electric Code C22.1' most current publication on I.S. installation guidelines. For GENELEC/ATEX applications, adhere to 'EN 60079-14:1997' or any equivalent, most current and pertaining publication on I.S. installation guidelines.
- 5- Warning: Substitution of components may impair the Intrinsic Safety of the unit. DO NOT open the unit when either energized or if an explosive gas/dust atmosphere is present. Disconnect power before servicing. Also read, understand and adhere to the manufacturer's installation and operating procedures.

		DO NOT SCALE DRAWING		CONTROL DRAWING		100-100-58		REVISION A			
		DRAWN Gus H. Elias 10/00		TITLE Field Installation Diagram: THZ-DH		REVISOR INITIAL RELEASE		DATE G.E. 10/00		BY CB	
TOLERANCES (UNLESS NOTED) DECIMALS = ± .001 / .0025 X = ± .01 / .025 XX = ± .03 / .076 XXX = ± .010 / 0.25 HOLES = +.003 / -.0024 / .08-.05 ANGLES = ± .30°		CHECKED W.Ho 10/00		ENGINEER Gus H. Elias 10/00		CATEGORY PC Prog. Smart HART Temp. X-mitter. Intrinsically Safe System For Hazardous 'Classified' Locations.		NOTICE RE PROPRIETARY INFORMATION: This drawing and the information contained herein are the proprietary property of Moore Industries International, Inc. (MI) and should not be reproduced or disclosed to any third party without the written consent of an authorized officer of MI.			

CERTIFIED PRODUCT

This is a controlled 'Related' or 'Schedule' drawing. No modifications are permitted without the notification and final approval of the Q.A. Certification Engineer (related dwgs.) or the Certifying Agency (schedule dwgs.).

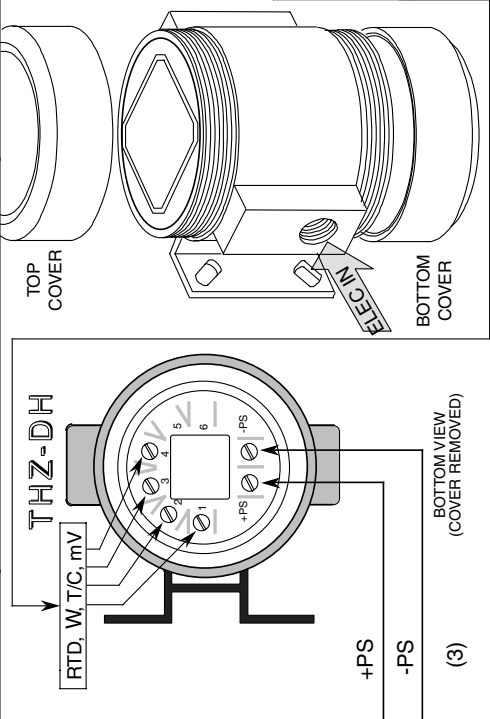

Entity Parameters (Power/Loop, +PS & -PS):
 V_{max} or U_i = 30 VDC
 I_{max} or I_i = 110 mA
 P_{max} or P_i = 0.825 W
 C_i = 13 nF
 L_i = 0 μ H
 Lo/Ro = 43.1 μ H/W

RTD, W, T/C, mV:
 C_a or C_o = 48 μ F
 L_a or L_o = 0.34 mH
 V_{oc} or V_t = 5.355 V
 I_{sc} or I_t = 314 mA
 P_o = 0.825 W

Input device must be 'Agency' approved per application area. (CSA, EECs, FM, IISSEF, LClE, SIR, SAA, TUV, etc...)

Hazardous (Classified) Locations/Areas:
 CSA International
 Intrinsically Safe: Class I, Div. 1 & 2, Groups A-D.
 Class II, Div. 1, Groups E, F & G.
 Class II, Div. 2, Groups F & G. Class III.
 GENELEC/ATEX

Intrinsically Safe: II 1G EEx ia IIC, T4 @ 60 °C

Hazardous (Classified) Locations - FMR (US NEC-500):
 Intrinsically Safe: Class I, II, III; Div. 1; Groups A-G.
 Non-Incendive: Class I, Div. 2, Groups A-D.
 Class II, Div. 2, Groups F & G and Class III, Div. 2.
 US NEC-505: Class I, Zone 0, AEx ia IIC, T4 @ 60 °C

T. Code: T4A @ 40 °C & T4 @ 60 °C
 Maximum Operating Ambient Temperature

Notes:

- (1) Apparatus which is unspecified except that it must not be supplied from, or contain under normal or abnormal conditions a source of potential with respect to earth in excess of 250 VRMS or 250 VDC which is considered to be the Safe Area's maximum voltage.
- (2) The Barrier or other Associated Apparatus must be approved by the "specific" (CSA/EECS/FM/LClE/SAA/SIRA/TUV, etc.) certifying agency for I.S. connections in: "Class III, Division 1, Groups A-G" or equivalent Zone classifications for Hazardous 'Classified' Locations. The output voltage (V_{oc} , V_t or V_o) must not exceed 30 VDC & the output current (I_{sc} , I_t or I_o) must not exceed 110 mA. Also, it must be installed per the manufacturer's guidelines. A Shunt Zener Barrier is NOT required for Non-Incendive (or Class I, Division 2 or Type N) installations.
- (3) The combined Capacitance and Inductance of the inter-connecting cables and the PC Prog. Transmitter must not exceed the values indicated on the Associated Apparatus.
- 4- For FM applications, installation must be in accordance to 'ANSI/ISA-PP12.6' (Installation of I.S. Systems for Hazardous 'Classified' Locations) and the National Electric Code 'ANSI/NFPA 70'. Also, a dust-tight conduit seal must be used when installed in Class II and Class III environments. For CSA applications, adhere to the 'Canadian Electric Code C22.1' most current publication on I.S. installation guidelines. For GENELEC/ATEX applications, adhere to 'EN 60079-14:1997' or any equivalent, most current and pertaining publication on I.S. installation guidelines.
- 5- **Warning:** Substitution of components may impair the unit's Intrinsic Safety and/or Non-Incendivity. **DO NOT** open the unit when either energized or when an explosive gas/dust atmosphere is present. Disconnect power before servicing. Also read, understand and adhere to the manufacturer's installation and operating procedures.

THZ & TDZ



Declaration of Conformity



EMC Directive 89/336/EEC

• **Manufacturer's Name:** Moore Industries-International, Inc.
 • **Manufacturer's Address:** 16650 Schoenborn Street
 Sepulveda, CA 91343-6196
 USA

Declares that the product(s):

• **Product Name:** THZ-DIN

MODEL	INPUT	OUTPUT	POWER	OPTIONS	HOUSING
-------	-------	--------	-------	---------	---------

THZ	*	*	*	*	*
-----	---	---	---	---	---

*Indicates any input, output, power, options, and housing as stated on product data sheet

• **Conforms to the following EMC specifications:**

EN 50081-2, 1993, Generic Emission Standard, Industry Environment
 EN 50082-2, 1995, Generic Immunity Standard, Industry Environment

• **Supplementary Information:**

None

14 January 2000

Date

Richard Ojeda
 Quality Assurance Manager

Robert Stockham
 Moore Industries-Europe General Mgr.

European Contact: Your Local Moore Industries Sales and Service Office



The Interface Solution Experts • www.miinet.com

United States • info@miinet.com
 Tel: (818) 894-7111 • FAX: (818) 891-2816
 Australia • sales@mooreind.com.au
 Tel: (02) 8536-7200 • FAX: (02) 9525-7296

Belgium • info@mooreind.be
 Tel: 03/448.10.18 • FAX: 03/440.17.97
 The Netherlands • sales@mooreind.nl
 Tel: (0)344-617971 • FAX: (0)344-615920

China • sales@mooreind.sh.cn
 Tel: 86-21-62491499 • FAX: 86-21-62490635
 United Kingdom • sales@mooreind.com
 Tel: 01293 514488 • FAX: 01293 536852



Declaration of Conformity



EMC Directive 89/336/EEC

- **Manufacturer's Name:** Moore Industries-International, Inc.
- **Manufacturer's Address:** 16650 Schoenborn Street
Sepulveda, CA 91343-6196
USA

Declares that the product(s):

- **Product Name:** THZ-HPP

MODEL /	INPUT /	OUTPUT /	POWER /	OPTIONS /	HOUSING
---------	---------	----------	---------	-----------	---------

- **Model Number(s):** THZ * * * * *

*Indicates any input, output, power, options, and housing as stated on product data sheet

Conforms to the following EMC specifications:

- EN 50081-1, 1992, Generic Emission Standard, Residential, Commercial and Light Industry
- EN 50082-1, 1992, Generic Immunity Standard, Residential, Commercial and Light Industry

Supplementary Information:

None

14 January 2000

Date

Richard Ojeda
Quality Assurance Manager

Robert Stockham
Moore Industries-Europe General Mgr.

European Contact: Your Local Moore Industries Sales and Service Office



The Interface Solution Experts • www.miinet.com

United States • info@miinet.com
 Tel: (818) 894-7111 • FAX: (818) 891-2816
 Australia • sales@mooreind.com.au
 Tel: (02) 8536-7200 • FAX: (02) 9525-7296

Belgium • info@mooreind.be
 Tel: 03/448.10.18 • FAX: 03/440.17.97
 The Netherlands • sales@mooreind.nl
 Tel: (0)344-617971 • FAX: (0)344-615920

China • sales@mooreind.sh.cn
 Tel: 86-21-62491499 • FAX: 86-21-62490635
 United Kingdom • sales@mooreind.com
 Tel: 01293 514488 • FAX: 01293 536852



Declaration of Conformity



EMC Directive 89/336/EEC

- **Manufacturer's Name:** Moore Industries-International, Inc.
- **Manufacturer's Address:** 16650 Schoenborn Street
Sepulveda, CA 91343-6196
USA

Declares that the product(s):

- **Product Name:** TDZ

MODEL	INPUT	OUTPUT	POWER	OPTIONS	HOUSING
-------	-------	--------	-------	---------	---------

- **Model Number(s):** TDZ * * * * *

* Indicates any input, output, power, options and housing as stated on the product data sheet

- **Conforms to the following EMC specifications:**
EN 50081-2, 1993, Generic Emission Standard, Industrial Environment
EN 50082-2, 1995, Generic Immunity Standard, Industrial Environment

- **Supplementary Information:**
None

14 January 2000

Date

Richard Ojeda
Quality Assurance Manager

Robert Stockham
Moore Industries-Europe General Mgr.

European Contact: Your Local Moore Industries Sales and Service Office



United States • info@miinet.com
Tel: (818) 894-7111 • FAX: (818) 891-2816
Australia • sales@mooreind.com.au
Tel: (02) 8536-7200 • FAX: (02) 9525-7296

Belgium • info@mooreind.be
Tel: 03/448.10.18 • FAX: 03/440.17.97
The Netherlands • sales@mooreind.nl
Tel: (0)344-617971 • FAX: (0)344-615920

China • sales@mooreind.sh.cn
Tel: 86-21-62491499 • FAX: 86-21-62490635
United Kingdom • sales@mooreind.com
Tel: 01293 514488 • FAX: 01293 536852

The Interface Solution Experts • www.miinet.com



Declaration of Conformity



EMC Directive 89/336/EEC

- **Manufacturer's Name:** Moore Industries-International, Inc.
- **Manufacturer's Address:** 16650 Schoenborn Street
Sepulveda, CA 91343-6196
USA

Declares that the product(s):

- **Product Name:** THZ-DH

MODEL /	INPUT /	OUTPUT /	POWER /	OPTIONS /	HOUSING
---------	---------	----------	---------	-----------	---------

- | | | | | | |
|-------------------------------|---|---|---|---|---|
| • Model Number(s): THZ | * | * | * | * | * |
|-------------------------------|---|---|---|---|---|

*Indicates any input, output, power, options, and housing as stated on product data sheet

- **Conforms to the following EMC specifications:**
EN 50081-2, 1993, Generic Emission Standard, Industry Environment
EN 50082-2, 1995, Generic Immunity Standard, Industry Environment

- **Supplementary Information:**
None

1 May 2000

Date

Richard Ojeda
Quality Assurance Manager

Robert Stockham
Moore Industries-Europe General Mgr.

European Contact: Your Local Moore Industries Sales and Service Office



The Interface Solution Experts • www.miinet.com

United States • info@miinet.com
Tel: (818) 894-7111 • FAX: (818) 891-2816
Australia • sales@mooreind.com.au
Tel: (02) 8536-7200 • FAX: (02) 9525-7296

Belgium • info@mooreind.be
Tel: 03/448.10.18 • FAX: 03/440.17.97
The Netherlands • sales@mooreind.nl
Tel: (0)344-617971 • FAX: (0)344-615920

China • sales@mooreind.sh.cn
Tel: 86-21-62491499 • FAX: 86-21-62490635
United Kingdom • sales@mooreind.com
Tel: 01293 514488 • FAX: 01293 536852

GUIDELINES AND CERTIFICATIONS

Low Voltage Directive

When installing any Moore Industries product, always follow all local regulations and standards for grounding, shielding, and safety. The following grounding and wiring practices must be followed in order for the unit(s) to meet the requirements set forth in the EMC directives EN50082-2 and EN55011.

Grounding

If the unit has a metal case it is to be grounded. (DIN rail mounted units should be mounted on a grounded rail).

Wiring

Twisted shielded wire should be used for all input and output signals. The shields are to be grounded at the units, to earth ground (safety ground). The un-shielded part of the in/output wires should be no longer than 2 inches.

CE Certification-related Guidelines

The following guidelines must be followed in order to comply with EN61010-1 (Low Voltage Directive). If these products are to be used in a non-CE environment, this directive may be disregarded.

WARNING:

If this unit is used in a manner not specified by Moore Industries, the protection provided by the equipment may be impaired.

Switches and Circuit Breakers

A switch or circuit breaker must be wired in series with the AC power conductors. The switch or circuit breaker used must be located within three meters of the unit.

WARNING:

Terminals on this unit may be connected to hazardous voltages. Before making ANY connections to this unit, ALL hazardous voltages must be de-energized.

The circuit breaker or switch will only remove power to the unit, hazardous voltages may still be connected to other terminals on the unit.

Installation Category

All of Moore Industries' terminals are rated CAT II, except those with the -RF option. These terminals are rated CAT I.

Equipment Ratings

The THZ and TDZ do not generate hazardous voltages, rather, they accommodate a temperature input, and generates a low voltage current output. Products connected to the THZ or TDZ should be designed to receive these inputs.

Supply Wiring

All power connections should be made with the proper wire.

The end of each conductor should be stripped no more than 8mm. The end of the stripped wire should be tinned with solder, or inserted into a ferrule and crimped before being placed into a terminal block.

Conductors connected to screw-type connections should have a ring-lug or spade-lug crimped onto the wire end.

RETURN PROCEDURES

To return equipment to Moore Industries for repair, perform the following:

1. Notify the local Moore Industries' Sales Representative or a factory Customer Service Representative that you are returning equipment for repair. Furnish the Moore Industries' representative with the model and serial number(s) of the equipment to be returned.
2. In a cover letter or note, describe completely the following:
 - a. the symptoms that indicate the equipment needs repair
 - b. the environment in which the equipment has been operating (vibration, temperature, etc.)
 - c. approximate number of operating hours or approximate installation date (if known)
 - d. complete shipping information for return of the equipment after repair
 - e. the name and phone number of the person to contact if questions arise at the factory
3. Enclose the cover letter, packing list, copies of rejection or discrepancy reports (if available), and purchase order or purchase order number with the equipment.
4. Use sufficient packing material and carefully pack the equipment in a sturdy shipping container.
5. Ship the equipment to the Customer Service Department nearest you.

The returned equipment will be inspected and tested at the factory. A Moore Industries' representative will contact the person designated in the cover letter if more information is needed.

In case of repair pursuant to Moore Industries' return policy, the defective equipment will be either replaced, or the purchase price refunded, at Moore Industries option. The equipment or its replacement will be returned to you in accordance with the shipping instructions furnished in your cover letter.

In other cases, the Moore Industries' representative will advise you of the repair cost and estimated return date, if requested in your letter. Repair in such instances must be authorized by a purchase order number before the equipment can be repaired and returned.

WARRANTY DISCLAIMER

THE COMPANY MAKES NO EXPRESS, IMPLIED OR STATUTORY WARRANTIES (INCLUDING ANY WARRANTY OF MERCHANTABILITY OR OF FITNESS FOR A PARTICULAR PURPOSE) WITH RESPECT TO ANY GOODS OR SERVICES SOLD BY THE COMPANY. THE COMPANY DISCLAIMS ALL WARRANTIES ARISING FROM ANY COURSE OF DEALING OR TRADE USAGE, AND ANY BUYER OF GOODS OR SERVICES FROM THE COMPANY ACKNOWLEDGES THAT THERE ARE NO WARRANTIES IMPLIED BY CUSTOM OR USAGE IN THE TRADE OF THE BUYER AND OF THE COMPANY, AND THAT ANY PRIOR DEALINGS OF THE BUYER WITH THE COMPANY DO NOT IMPLY THAT THE COMPANY WARRANTS THE GOODS OR SERVICES IN ANY WAY.

ANY BUYER OF GOODS OR SERVICES FROM THE COMPANY AGREES WITH THE COMPANY THAT THE SOLE AND EXCLUSIVE REMEDIES FOR BREACH OF ANY WARRANTY CONCERNING THE GOODS OR SERVICES SHALL BE FOR THE COMPANY, AT ITS OPTION, TO REPAIR OR REPLACE THE GOODS OR SERVICES OR REFUND THE PURCHASE PRICE. THE COMPANY SHALL IN NO EVENT BE LIABLE FOR ANY CONSEQUENTIAL OR INCIDENTAL DAMAGES EVEN IF THE COMPANY FAILS IN ANY ATTEMPT TO REMEDY DEFECTS IN THE GOODS OR SERVICES, BUT IN SUCH CASE THE BUYER SHALL BE ENTITLED TO NO MORE THAN A REFUND OF ALL MONIES PAID TO THE COMPANY BY THE BUYER FOR PURCHASE OF THE GOODS OR SERVICES.

ANY CAUSE OF ACTION FOR BREACH OF ANY WARRANTY BY THE COMPANY SHALL BE BARRED UNLESS THE COMPANY RECEIVES FROM THE BUYER A WRITTEN NOTICE OF THE ALLEGED DEFECT OR BREACH WITHIN TEN DAYS FROM THE EARLIEST DATE ON WHICH THE BUYER COULD REASONABLY HAVE DISCOVERED THE ALLEGED DEFECT OR BREACH, AND NO ACTION FOR THE BREACH OF ANY WARRANTY SHALL BE COMMENCED BY THE BUYER NO LATER THAN TWELVE MONTHS FROM THE EARLIEST DATE ON WHICH THE BUYER COULD REASONABLY HAVE DISCOVERED THE ALLEGED DEFECT OR BREACH.

RETURN POLICY

For a period of thirty-six (36) months from the date of shipment, and under normal conditions of use and service, Moore Industries ("The Company") will at its option replace, repair or refund the purchase price for any of its manufactured products found, upon return to the Company (transportation charges prepaid and otherwise in accordance with the return procedures established by The Company), to be defective in material or workmanship. This policy extends to the original Buyer only and not to Buyer's customers or the users of Buyer's products, unless Buyer is an engineering contractor in which case the policy shall extend to Buyer's immediate customer only. This policy shall not apply if the product has been subject to alteration, misuse, accident, neglect or improper application, installation, or operation. THE COMPANY SHALL IN NO EVENT BE LIABLE FOR ANY INCIDENTAL OR CONSEQUENTIAL DAMAGES.



The Interface Solution Experts • www.miinet.com

United States • info@miinet.com Tel: (818) 894-7111 • FAX: (818) 891-2816	Belgium • info@mooreind.be Tel: 03/448.10.18 • FAX: 03/440.17.97	China • sales@mooreind.sh.cn Tel: 86-21-62491499 • FAX: 86-21-62490635
Australia • sales@mooreind.com.au Tel: (02) 8536-7200 • FAX: (02) 9525-7296	The Netherlands • sales@mooreind.nl Tel: (0)344-617971 • FAX: (0)344-615920	United Kingdom • sales@mooreind.com Tel: 01293 514488 • FAX: 01293 536852