

# TUpH™ Retraction/Submersion/Insertion pH/ORP Sensors



- **SILCORE™<sup>3</sup> TECHNOLOGY PROVIDES INCREASED SENSOR LIFE** when used in elevated temperature applications.
- **QUICK CABLE-TO-SENSOR RELEASE**, provided by the watertight VP 6.0 connector, eliminates cable twisting.
- **MINIMUM SENSOR MAINTENANCE** due to patented TUpH reference technology<sup>1</sup> which ensures steady pH signal when sensor is coated.
- **MAXIMUM SENSOR LIFE** because of secondary helical reference pathway<sup>2</sup> which hinders reference poisoning.
- **FIELD PROVEN ACCUGLASS™<sup>3</sup> pH glass formulations** minimize glass cracking, resulting in enhanced performance and increased life.
- **OPTIMUM VERSATILITY** by providing various mounting options. Also can be used with all Rosemount Analytical and other manufacturers' instruments.
- **SUPERIOR CHEMICAL RESISTANCE** through choice of sensor construction materials to battle many aggressive elements.

## FEATURES (depending on sensor model):

**Sensor Tube Materials:** 316 SST or Titanium

**Reference Materials:** Polypropylene or Tefzel<sup>4</sup>

**Wetted Seals:** EPDM, Viton<sup>®4</sup>, or Kalrez<sup>®4</sup>

**pH Glass Style:** Flat or Hemi bulb

**Insertion Depths:** 2.1 inches to 27 inches (5.3 cm to 68.6 cm)

**Sensor Design:** Threaded connection for in-line or submersion mounting or ball valve retractable

**Temperature Compensation:** 3K or Pt100

**Operating Temperature:** 0° to 100°C (32° to 212°F)

**Operating Pressure:** 0 to 250 psig (100 to 1825 kPa [abs])



**MODEL 396VP & 398VP**  
Insertion/Submersion Sensors



**MODEL 396R VP & 398R VP**  
Ball Valve  
Retractable Sensors

<sup>1</sup> May be protected by U.S. Patent No. 5,152,882, Foreign Patent Pending.

<sup>2</sup> May be protected by U.S. Patent No. 6,054,031, Foreign Patent Pending.

<sup>3</sup> SILCORE, ACCUGLASS and TUpH are trademarks of Rosemount Analytical.

<sup>4</sup> Tefzel and Viton are registered trademarks of DuPont Performance Elastomers.

**The TUpH large area reference junction for minimum maintenance requirements:** The reference junction provides an electrical connection between the reference electrode and the sample, and helps maintain a stable reference potential, regardless of the change in sample pH. The TUpH reference electrode junction, the entire plastic tip surrounding the glass pH electrode, maintains a steady reference signal even in the dirtiest of applications because it resists plugging (a common cause of pH signal drift). This large reference junction area is made of micron sized reference pathways used for ionic exchange so it resists plugging by large particles and will continue to send a steady pH signal, even in the dirtiest of applications. The TUpH reference junction technology has been field-proven for minimum maintenance requirements.

**The TUpH helical reference pathway stops reference poisoning.** Ions diffuse through the reference pathways and a charge is passed to the reference element. The reference element must be protected from contamination by poisoning ions such as sulfide, mercury, cyanide, and ammonia or else the pH signal will drift. The TUpH sensor's long internal helical reference pathway hinders and slows down the rate of contaminants migrating to the reference element therefore providing for a longer sensor life.

**The entire line of TUpH model sensors now incorporate the new SILCORE technology contaminant barrier.** This triple-seal barrier prevents moisture and material impurities from migrating to the pH sensor's reference electrode's

metal lead wire. By preventing these contaminants from compromising the integrity of the pH measurement, sensor life is increased, especially at higher temperatures where increased migrations occur. In addition, the SILCORE technology provides added protection against sensor failure due to vibrations and shock by transferring damaging energy away from the glass-to-metal seal.

**The AccuGLASS pH glass formulations exceed industry standards.** The AccuGlass pH glass is a result of many years of glass research resulting in a formulation which has been found to increase the life of the sensor. Unlike other pH glasses presently on the market, this glass resists cracking especially at higher temperatures and reduces sodium ion error commonly found in high pH applications. Overall, the AccuGlass formulation enhances the sensor performance to measure pH more accurately and have a longer sensor life than ever before.

**The TUpH reference junction and helical pathway combined with the AccuGLASS pH glass** performs exceptionally well in dirty, high solid applications and requires only minimum maintenance. This is the toughest pH sensor on the market and is still unmatched by all other pH sensors. The constant increase in demand for the TUpH sensor proves it's success as the best process industry pH sensor.

**All TUpH sensor models** have been specifically designed for improved life in harsh, dirty, and abrasive applications such as lime slurry, waste treatment, paper machine head-box, and pigment/dye applications, where large quantities of suspended solids are present. Various sensor materials, depending on the sensor model, is available for a variety of different application needs.

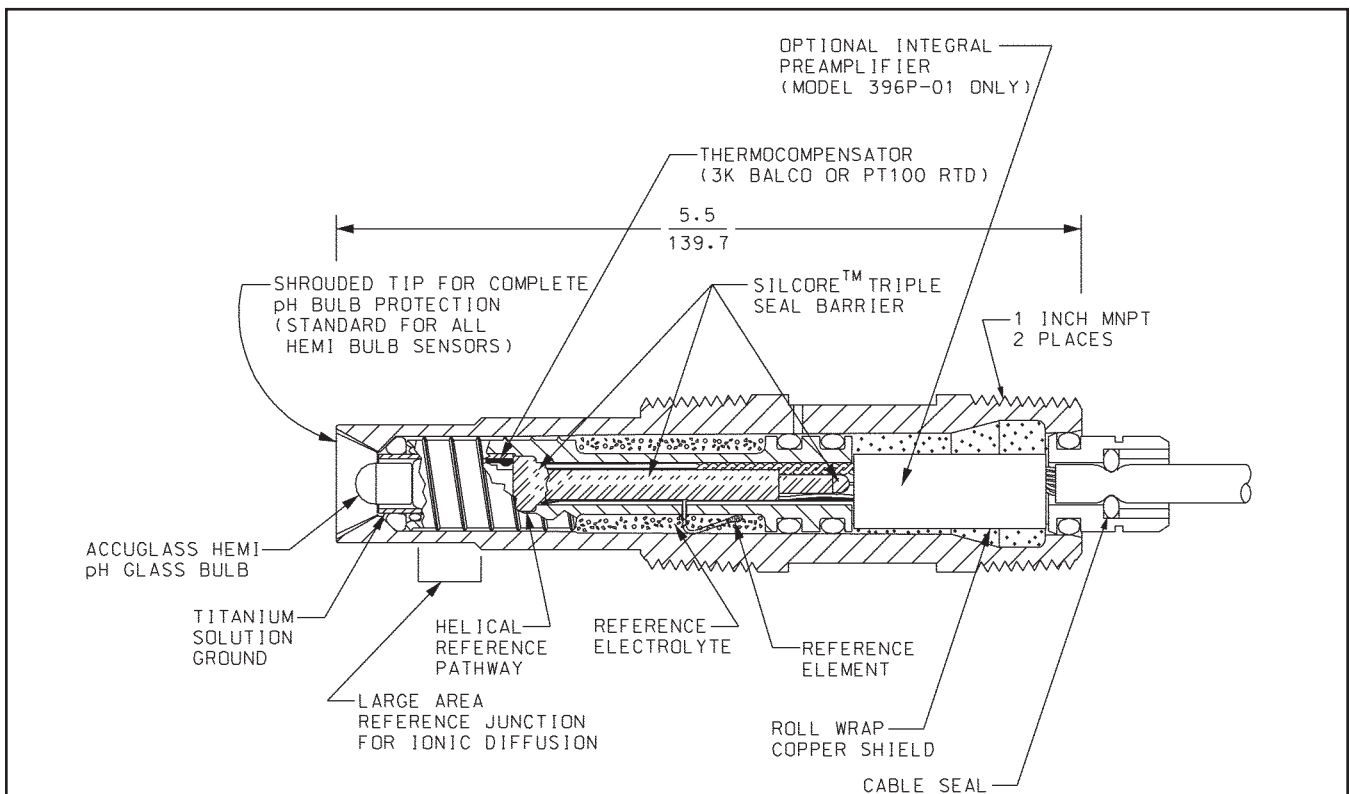

**Cross Section Diagram of the TUpH Patented Reference Technology**

*All TUpH sensors are designed with a large area reference junction, helical reference pathway, and an AccuGlass pH glass bulb. This patented sensor technology ensures superior performance while only requiring minimal maintenance.*

## FEATURES AND APPLICATIONS (cont.)

**A choice of flat or hemi glass pH glass electrodes** is available on all sensor models to best meet various application needs. Flat glass is advantageous in abrasive or coating applications that etch or build up on glass, respectively. In coating applications, such as slurries, the flat surface allows the process flow to act as a scrubbing agent to reduce coating and maintenance. In abrasive applications pitting from silicates and other similar materials is minimized by the flat glass surface to provide longer sensor life. Flat glass sensors are offered with a flat tip which is flush with the flat glass (Models 396VP and 398VP; see example below) or a slotted tip for added protection to the ball valve retractable flat glass (Models 396RVP and 398RVP; see example below). The hemi bulb glass is ideal for general purpose use and for those processes requiring greater accuracy over the entire pH range. All hemi bulb sensors are offered with a standard slotted tip which partially surrounds the glass bulb for protection against solids and yet allows the process to flow by the glass electrode for accurate and reliable pH measurement. Both pH glass bulbs — the standard hemi or optional flat pH glass — are exceptional for increased resistance to high temperature and other effects of aging for longer life.

### Examples of both sensing tip offerings



**Standard Slotted Tip** available on all hemi bulb sensors and retractable flat bulb sensors



**Optional Flat Tip** available with flat glass bulb insertion/submersion sensor models

**A preamplifier converts the high impedance pH signal into a stable, noise-free signal** and must be used with all pH sensors. A preamplifier can be in a remote location or integral to the analyzer/transmitter and has transmission capability of up to three miles. All TUpH Sensors are compatible with all Rosemount Analytical and other manufacturers' instruments.

**A watertight sensor-to-cable connector eliminates re-wiring and cable twisting** when replacing sensors. The Variopol VP 6.0 connector is an integral part of each sensor model and uses a mating VP cable; see example below. Once the cable is installed and wired to the analyzer, sensors are easily replaced



**Variopol connector** shown with mating variopol cable receptacle

without replacing the cable, and, if the replacement sensor is the same as its predecessor, without rewiring the analyzer. Note: switching between diagnostic and non-diagnostic sensors may require changes to the wiring at the instrument. Also the cable can be disconnected from the sensor before removal from the process which eliminates cable twisting.

**A choice of sensor wetted materials** is available for maximum chemical resistance. Check sensor model specifications on page 4 or ordering matrices on pages 8 and 10 for various wetted materials.

**Models 396VP and 398VP insertion/submersion sensors** are housed in a short metal sensor tube and use a one inch compression fitting for process connection. The sensors are sealed from the process by an elastomer o-ring of EPDM, Viton, or Kalrez depending on sensor model. The simplified construction, designed with the user convenience in mind, does not require electrolyte replenishment or any component replacement.



**Model 396VP and 398VP**

**Models 396RVP and 398RVP ball valve retractable sensors** are housed in a 21 or 36 inch titanium sensor tube and is sealed from the process by an elastomer o-ring of EPDM, Viton, or Kalrez, depending on sensor model, for maximum chemical resistance. These two models were specifically designed for applications where a separate sample stream is difficult to provide and greater insertion depths are required. Both can be used with a 1-¼ in. or 1-½ in. ball valve for hot tap installations. **Model 396RVP features a titanium solution ground for advanced sensor diagnostics** when used with the Models 54, 81, 3081, and 4081 pH/ORP analyzers/transmitters. Advanced sensor diagnostics aid preventative maintenance by notifying the operator of the need for replacing or cleaning an aged or fouled sensor, thus allowing continuous optimum performance.

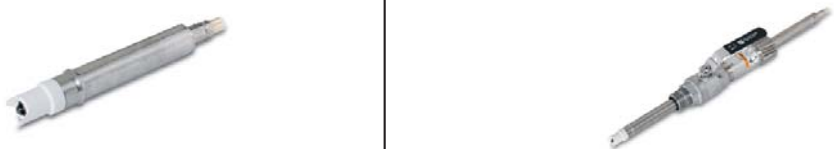

**Model 396RVP and 398RVP, shown in an optional ball valve kit**

SPECIFICATIONS				
	MODEL 396VP	MODEL 398VP	MODEL 396RVP	398RVP
<b>Measurements and Ranges</b>	pH: 0-14	pH: 0-14 ORP: -1500 to 1500 mv	pH: 0-14 ORP: -1500 to 1500 mv	pH: 0-14 ORP: -1500 to 1500 mv
<b>Available pH AccuGLASS Types</b>	GPHT hemi bulb or GPLR flat bulb	GPHT hemi bulb or GPLR flat bulb	GPLR hemi bulb or GPLR flat bulb	GPHT hemi bulb or GPLR flat bulb
<b>Wetted Materials</b>	316 SST, Polypropylene, EPDM, glass	Titanium, Tefzel, glass, choice of Kalrez, Viton, or EPDM (platinum: ORP only)	Titanium, Polypropylene, EPDM, glass (platinum: ORP only)	Titanium, Tefzel, glass, choice of Kalrez, Viton, or EPDM (platinum: ORP only)
<b>Process Connection</b>	None, use 1 in. NPT process connector, PN 23166-00 or 23166-01 (sold separately)	None, use 1 in. NPT process connector, PN 23166-00 or 23166-01 (sold separately)	None, use 1-in. process connector or ball valve kit (1-1/2 in. or 1-1/4 in.) (sold separately)	None, use 1-in. process connector or ball valve kit (1-1/2 in. or 1-1/4 in.) (sold separately)
<b>Temperature Range</b>	0-100°C (32-212°F)	0-100°C (32-212°F)	0-100°C (32-212°F)	0-100°C (32-212°F)
<b>Pressure Range-Hemi bulb</b>	100-1136 kPa (abs) (0-150 psig)	100-1825 kPa (abs) (0-250 psig)	100-1136 kPa (abs) (0-150 psig)	100-1825 kPa (abs) (0-250 psig)
<b>Pressure Range-Flat bulb</b>	100-790 kPa (abs) (0-100 psig)	100-790 kPa (abs) (0-100 psig)	100-790 kPa (abs) (0-100 psig)	100-790 kPa (abs) (0-100 psig)
<b>Maximum Pressure at Retraction or Insertion</b>	Not Applicable	Not Applicable	Code 21: 542 kPa (abs) (64 psig) Code 25: 343 kPa (abs) (35 psig)	Code 21: 542 kPa (abs) (64 psig) Code 25: 343 kPa (abs) (35 psig)
<b>Minimum Conductivity</b>	75 µS/cm, nominal	75 µS/cm, nominal	75 µS/cm, nominal	75 µS/cm, nominal
<b>Preamplifier Options</b>	Remote	Remote	Remote	Remote
<b>Weight/Shipping Weight</b>	0.45 kg/0.9 kg (1 lb/2 lb)	0.45 kg/0.9 kg (1 lb/2 lb)	Sensor: Code 21: 0.9 kg/1.40 kg (2.0 lb/3.0 lb) Code 25: 1.40 kg/1.80 kg (3.0 lb/4.0 lb) Ball Valve Kits: 2.25 kg/3.20 kg (5.0 lb/7.0 lb)	Sensor: Code 21: 0.9 kg/1.40 kg (2.0 lb/3.0 lb) Code 25: 1.40 kg/1.80 kg (3.0 lb/4.0 lb) Ball Valve Kits: 2.25 kg/3.20 kg (5.0 lb/7.0 lb)

PERCENT LINEARITY			
	396VP, 398VP, 398RVP	396RVP	396VP, 398VP, 396RVP, 398RVP
pH Range	GPHT Hemi	GPLR Hemi	GPLR Flat
0-2 pH	94%	94%	93%
2-12 pH	99%	97%	98%
12-13 pH	97%	98%	95%
13-14 pH	92%	98%	—

INCH  
MILLIMETER

## DIMENSIONAL DRAWINGS: Model 396VP and 398VP Shown with Process Connector

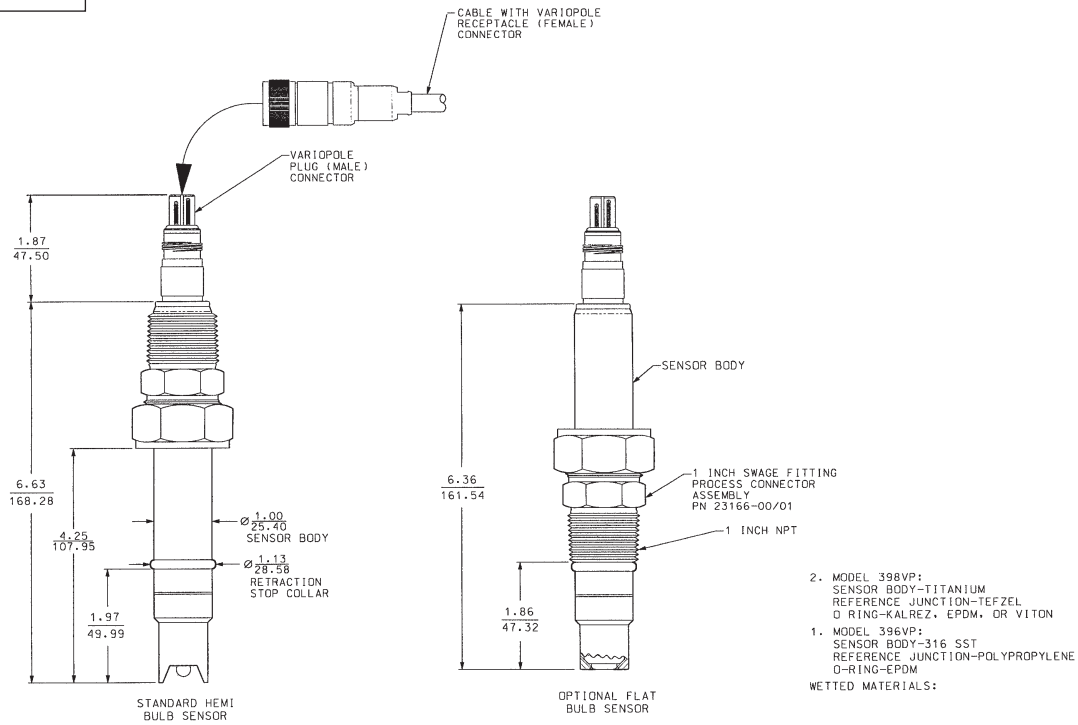

Metal Process Connector PN 23166-xx (xx = 00 for 316 SST and xx = 01 for titanium) can be used for insertion or submersion mounting of Models 396VP or 398VP sensors in 1-inch fittings.

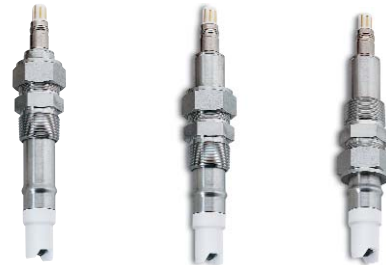

The metal process connector gives the sensor various insertions depths, depending on where the user locates the compression fitting. Also the threads can be switched to face the cable end of the sensor for connection to submersion pipes.

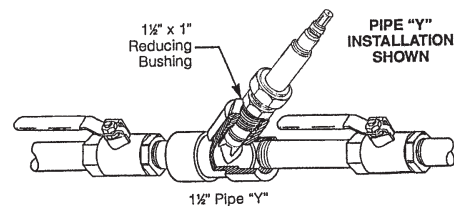
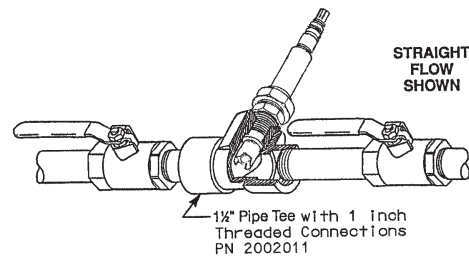
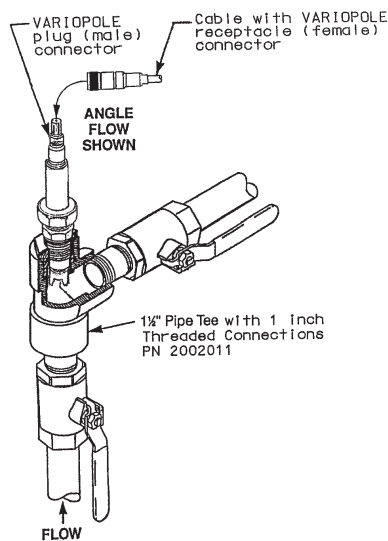

### Typical Flow Thru and Insertion Mounting Configurations for Models 396VP and 398VP

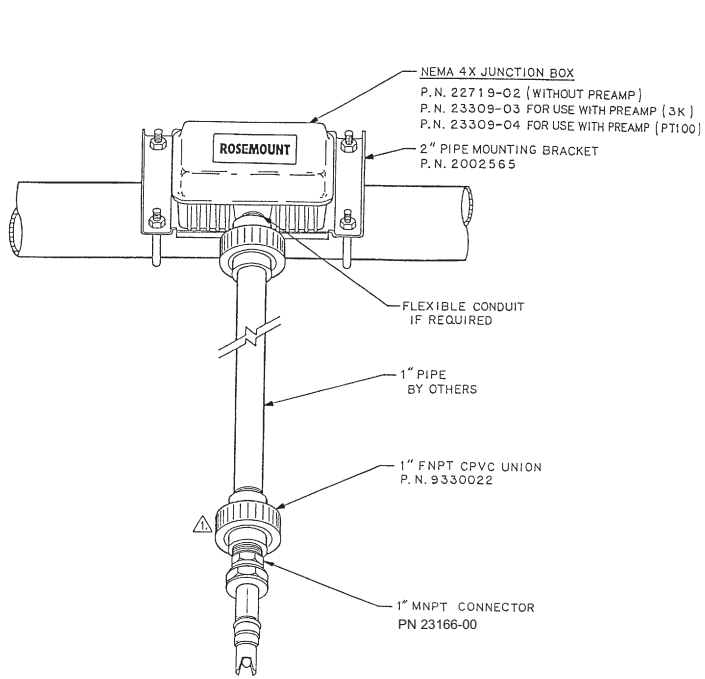

The Pipe Mounting Union (PN 9330022) is ideal for connecting a sensor to a pipe, tank, aeration basin, or open channel.

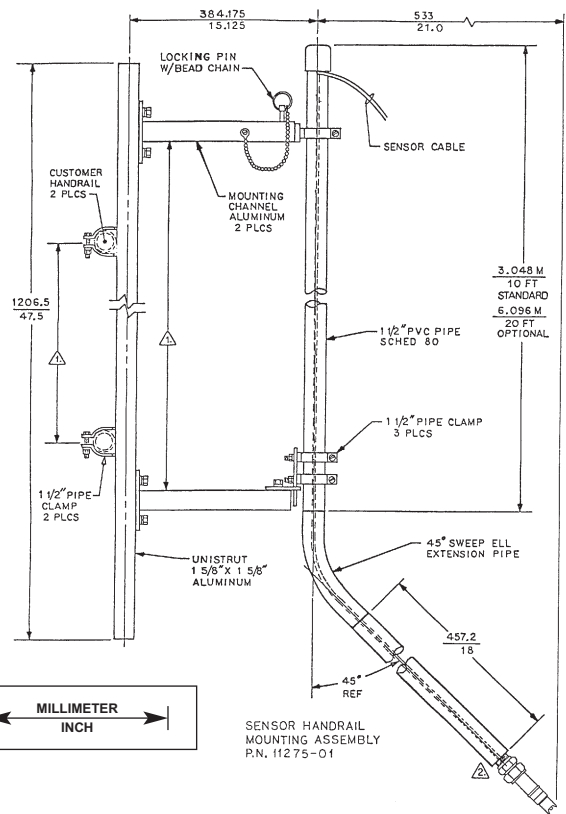

The Sensor Handrail Mounting Assembly (PN 11275-01) can be used to insert the sensor into tanks and ponds, and mounts easily on most handrails.

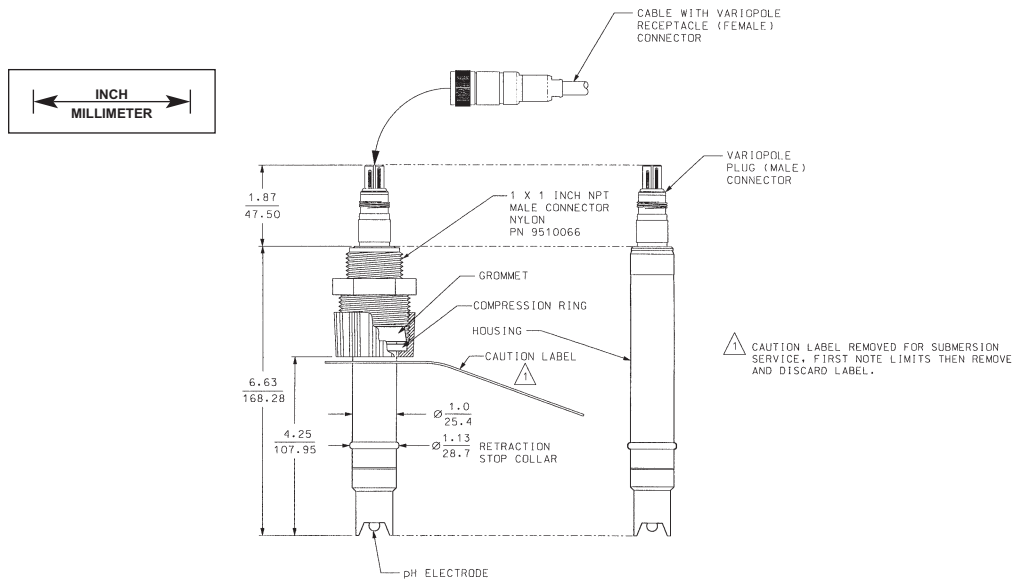

The Nylon Process Connector has process threads that can be used for submersion pipe or in-line tee mounting.

### Typical Submersion Installations for Models 396VP and 398VP



### DIMENSIONAL DRAWINGS: Model 396RVP and 398RVP with Optional 1-1/2 inch Ball Valve PN 23240-00



Ball Valve Kit (PN 23240-00) used with Model 396RVP and 398RVP retractable sensors



A process connector (PN 23166-00 or -01) must be used to connect the sensor to Ball Valve Kit 23240-00. Process connector can be purchased separately.

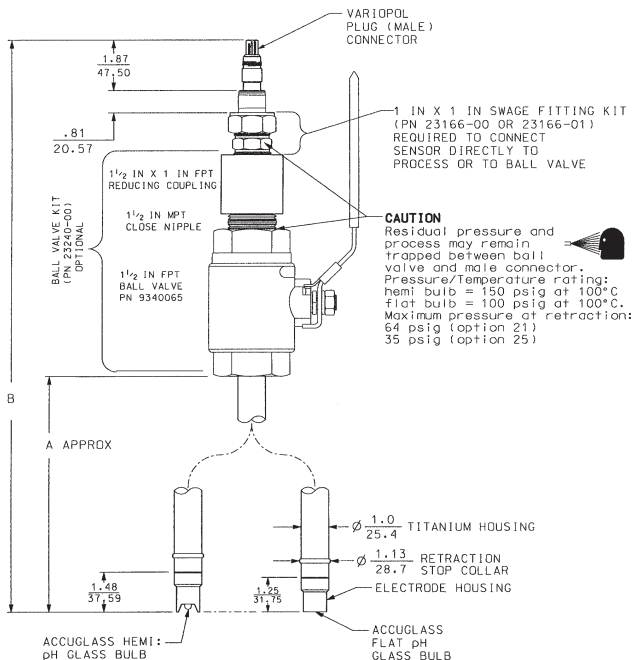

A		B		OPTION
IN / MM	IN / MM	IN / MM	IN / MM	
12.62/320.55	24.14/613.16			21
27.12/688.85	38.64/981.46			25

A		B		OPTION
IN / MM	IN / MM	IN / MM	IN / MM	
12.65/321.31	23.89/606.81			21
27.15/689.15	38.39/975.11			25



### DIMENSIONAL DRAWINGS: Model 396RVP and 398RVP with Optional 1-1/4 inch Ball Valve PN 23765-00

A		B		C		OPTION
IN / MM	IN / MM	IN / MM	IN / MM	IN / MM	IN / MM	
21.60/548.64	12.12/307.85	24.14/613.16				21
36.10/916.94	26.62/676.15	38.64/981.46				25

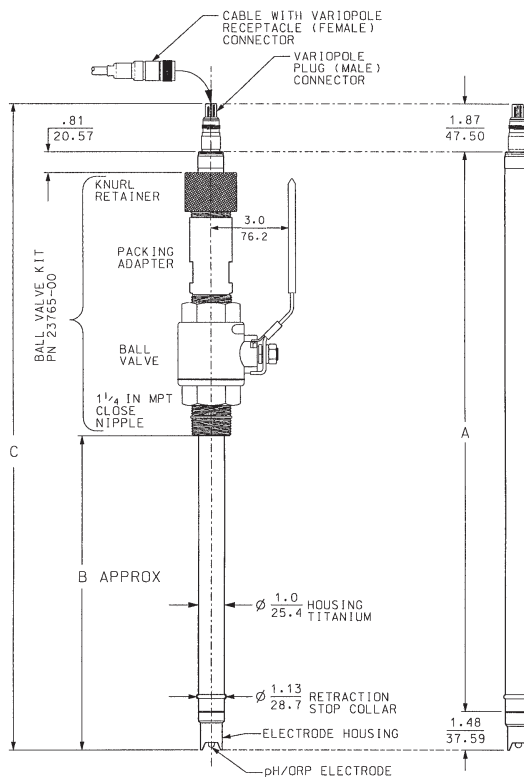



## ORDERING INFORMATION



The Models 396VP and 398VP insertion/submersion sensors feature a gel-filled electrolyte solution with the large area, coating resistant TUpH reference junction in a choice of polypropylene (Model 396VP) or Tefzel (Model 398VP) materials and a standard hemi or optional flat glass bulb. Both models are housed in a metal sensor tube, 316 SST for Model 396VP or Titanium for Model 398VP, and can be mounted in insertion, submersion, or flow through installations using a 1 in. MNPT threaded process connector (ordered separately). Both models are offered with the watertight Variopol sensor-to-cable connector and use the mating connector cable (ordered separately). Also available is a choice of temperature element, 3 K Balco or Pt 100 RTD. A remote preamplifier found in the analyzer/transmitter or in a junction box (ordered separately) must be used with these sensors for a reliable signal transmission.

MODEL 396VP		TUpH INSERTION/SUBMERSION STAINLESS STEEL AND POLYPROPYLENE pH SENSOR (GPHT hemi bulb)
CODE	ANALYZER/TC COMPATIBILITY (Required Selection)	
50	For use with Models 1181, 1050, 1003 (3 K TC)	
54	For use with Models 54, 1054, 1054A, 1054B, 2054, 2081, 2700, 81, 3081, 4081 and SCL-P (Pt 100 RTD)	
CODE	OPTIONAL OPTIONS	
71	GPLR Flat bulb	
<b>396VP - 54</b>		<b>EXAMPLE</b>

MODEL 398VP		TUpH INSERTION/SUBMERSION TITANIUM AND TEFLON pH/ORP SENSOR
CODE	MEASURING ELECTRODE TYPE (Required Selection)	
10	GPHT hemi glass, General Purpose High Temperature (0-14 pH)	
12	ORP	
13	Flat	
CODE	O-RING MATERIAL (Required Selection)	
30	EPDM	
31	Viton	
32	Kalrez (recommended for applications with Chlorine Dioxide)	
CODE	ANALYZER/TC COMPATIBILITY (Required Selection)	
50	For Models 1181 (3K TC) [no T.C. if ordered with option -12 (ORP)]	
54	For Models 1054, 1054A/B, 2054, 2081, 54, 4081, 3081, 81, SCL-(P/Q), Solu Cube (PT 100 RTD)	
<b>398VP - 10 - 32 - 54</b>		<b>EXAMPLE</b>

**FOR FIRST TIME 396VP AND 398VP INSTALLATIONS, ROSEMOUNT ANALYTICAL RECOMMENDS USING THE FOLLOWING GUIDE:**

<p><b>1. Variopool Cable (required for all first time installations)</b></p> <p>Choose one: PN 23645-06, 15 ft cable with mating VP connector, prepped with BNC on analyzer end  PN 23645-07, 15 ft cable with mating VP connector, prepped without BNC on analyzer end*</p> <p><b>2. Process Connector Accessories (required for all first time installations)</b></p> <p>Choose one: PN 23166-00, 316 SST, 1 in. x 1 in. NPT process connector (see page xx)  PN 23166-01, Titanium, 1 in. x 1 in. NPT process connector (see page xx)  PN 9510066, Nylon, 1 in. x 1 in. NPT process connector (see page xx)</p> <p>Choose one (optional process connector o-rings):  PN 9550220, Kalrez o-ring, 2-214  PN 9550099, Viton o-ring, 2-214</p> <p><b>3. Mounting Accessories (optional)</b></p> <p>Choose one: PN 2002011 CPVC flow through tee, 1 in. NPT process connection (see page xx)  PN 11275-01 PVC handrail mounting assembly, 1 in. NPT process connection (see page xx)  PN 915240-05 CPVC pipe mount union, 1 in. FNPT process connection (see page xx)</p> <p><b>4. Remote Junction Boxes (optional)</b></p> <p>Choose one: PN 23555-00 includes preamplifier for Models 54, 81, 3081, 4081  PN 23309-03 and PN 22698-02 plug-in preamplifier for Model 1181 Analyzer  PN 23309-04 and PN 22698-03 plug-in preamplifier for Models 1054 series, 2054, 2081 Analyzers  PN 23054-03 includes preamplifier for Solu Cube Model 2700</p> <p><b>5. Extension cables (used with remote junction boxes)</b></p> <p>Choose one: PN 23646-01, 11 conductor, shielded, prepped  PN 9200273, 11 conductor, shielded, unprepped</p>
--

\* Used for connections to Models 1181, 1054, 2081, 54, 81, 3081, 4081, and remote junction box PN 23555-00.

**WHAT'S THE DIFFERENCE BETWEEN THESE TWO MODELS?**

Both Model 396VP and 398VP are excellent for use in dirty, harsh applications where large quantities of suspended solids are found. The differences between the two models are listed in the table below.

Model	Sensor Tube Material	TupH Reference Junction Material	Choice of O-ring Material?	Typical Applications
396VP	316 SST	Polypropylene	No	Lime slurry, waste treatment, paper machine head box, and pigment/dye processes
398VP	Titanium	Tefzel	Yes	Chemically challenging applications, such as chlorine dioxide found in pulp bleaching towers, sour water strippers, and other process streams containing a variety of organic solvents.



**ORDERING  
INFORMATION**



The Models 396RVP and 398RVP ball valve retractable sensors feature a gel-filled electrolyte solution with the large area, coating resistant TUpH reference junction in a choice of polypropylene (Model 396RVP) or Tefzel (Model 398RVP) materials and a standard hemi or optional flat glass bulb. Both models are housed in a Titanium sensor tube and can be mounted directly into the process using a 1 in. MNPT threaded process connector and a ball valve assembly kit (both ordered separately). Both models are offered with the watertight Variopol sensor-to-cable connector and use the mating connector cable (ordered separately). Also available is a choice of temperature element, 3 K Balco or Pt 100 RTD. A remote preamplifier found in the analyzer/transmitter or in a junction box (ordered separately) must be used with these sensors for a reliable signal transmission.

MODEL 396RVP TUpH RETRACTABLE POLYPROPYLENE pH/ORP SENSOR	
CODE	MEASURING ELECTRODE TYPE (Required Selection)
10	Hemi bulb, General Purpose Low Resistivity (0-14 pH)
12	ORP
13	Flat, GPLR glass
CODE	SENSOR LENGTH (Required Selection)
21	21 in. Titanium Tube
25	36 in. Titanium Tube
CODE	ANALYZER/TC COMPATIBILITY (Required Selection)
50	For Models 1181 (3K TC)
54	For Models 1054, 1054A, 1054B, 2054, 2081,54, 3081, 4081, 81, SCL-(P/Q), 2700 (Pt 100 RTD)
<b>396RVP - 10 - 21 - 54 EXAMPLE</b>	

MODEL 398RVP TUpH RETRACTABLE TEFZEL pH/ORP SENSOR	
CODE	MEASURING ELECTRODE TYPE (Required Selection)
10	GPHT hemi glass, General Purpose High Temperature (0-14 pH)
12	ORP
13	Flat, GPLR glass
CODE	SENSOR LENGTH (Required Selection)
21	21 in. Titanium Tube
25	36 in. Titanium Tube
CODE	O-RING MATERIAL (Required Selection)
30	EPDM
31	Viton
32	Kalrez (recommended for applications with Chlorine Dioxide)
CODE	ANALYZER/TC COMPATIBILITY (Required Selection)
50	For Models 1181 (3K TC) [no T.C. if ordered with option -12 (ORP)]
54	For Models 1054, 1054A/B, 2054, 2081,54, 3081, 81, SCL-(P/Q), Solu Cube (PT 100 RTD)
<b>398RVP - 10 - 21 - 32 - 54 EXAMPLE</b>	



## ORDERING INFORMATION

FOR FIRST TIME 396RVP AND 398RVP INSTALLATIONS, ROSEMOUNT ANALYTICAL RECOMMENDS USING THE FOLLOWING GUIDE:

### 1. Variopool Cable (required for all first time installations)

- Choose one: PN 23645-06, 15 ft cable with mating VP connector, prepped with BNC on analyzer end  
 PN 23645-07, 15 ft cable with mating VP connector, prepped without BNC on analyzer end\*

### 2. Retractable Mounting

- 1A. Choose one (required for all first time installations, except as noted):  
 PN 23166-00 1 in. x 1 in. NPT process connector, 316 SST  
 PN 23166-01 1 in. x 1 in. NPT process connector, Titanium

Choose one (optional process connector o-rings):

- PN 9550220, Kalrez o-ring, 2-214  
 PN 9550099, Viton o-ring, 2-214

1B. Choose one:

- PN 23240-00 1-1/2 in. ball valve assembly, 316 SST  
 PN 23765-00 1-1/4 in. ball valve assembly, 316 SST (process connector not needed)

### 3. Remote Junction Boxes (Optional)

- Choose one: PN 23555-00 includes preamplifier for Models 54, 81, 3081, 4081  
 PN 23309-03 and PN 22698-02 plug-in preamplifier for Model 1181 Analyzer  
 PN 23309-04 and PN 22698-03 plug-in preamplifier for Models 1054 series, 2054, 2081 Analyzers  
 PN 23054-03 includes preamplifier for Solu Cube Model 2700

### 4. Extension cables

- Choose one: PN 23646-01, 11 conductor, shielded, prepped  
 PN 9200273, 11 conductor, shielded, unprepped

\* Used for connections to Models 1181, 1054, 2081, 54, 81, 3081, 4081, and remote junction box PN 23555-00.

## WHAT'S THE DIFFERENCE BETWEEN THESE TWO MODELS?

Both Model 396RVP and 398RVP are excellent for use in dirty, harsh applications where large quantities of suspended solids are found. The differences between the two models are listed in the table below.

Model	TUpH Reference Junction Material	Choice of O-ring Material?	Typical Applications
396RVP	Polypropylene	No	Lime slurry, waste treatment, paper machine head box, and pigment/dye processes
398RVP	Tefzel	Yes	Chemically challenging applications, such as chlorine dioxide found in pulp bleaching towers, sour water strippers, and other process streams containing a variety of organic solvents.

## TYPICAL MOUNTING CONFIGURATIONS FOR MODELS 396RVP AND 398RVP

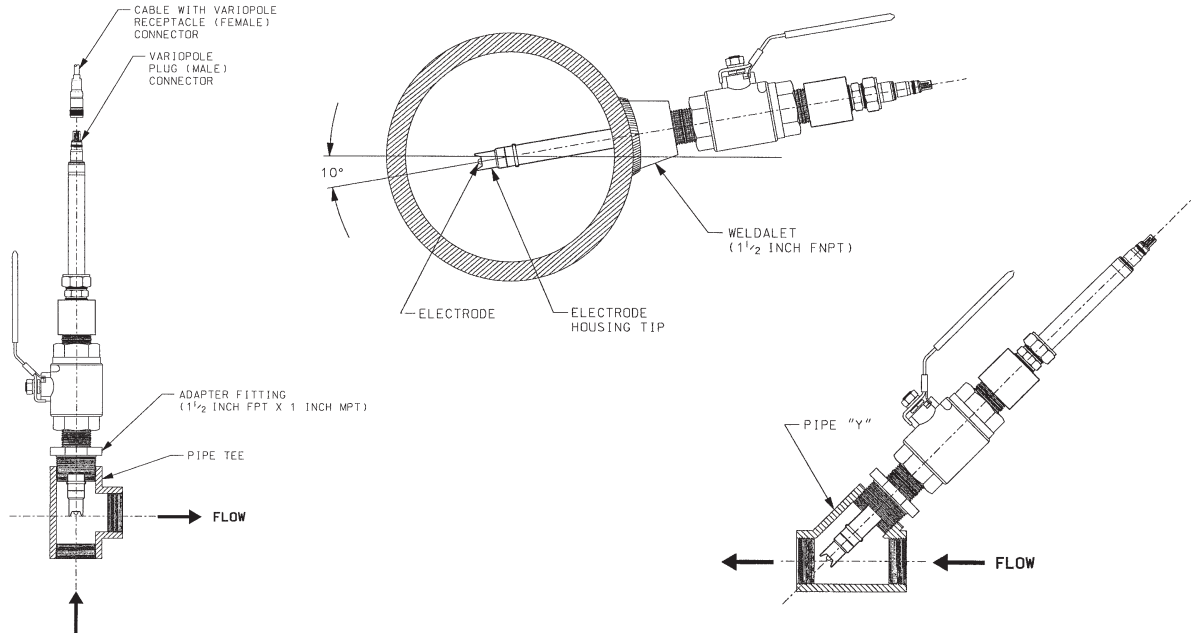

## OTHER ACCESSORIES

PART	DESCRIPTION
22698-00	Preamplifier plug-in for junction box, for Model 1003,
22698-02	Preamplifier plug-in for junction box, for Models 1181, 1050
22698-03	Preamplifier plug-in for junction box, for Models 1054A/B, 2054, 2081
22743-01	Pt100 preamplifier for Model 1181
22744-01	3K Preamplifier for Model 1181
23557-00	Preamplifier for junction box for Models 54, 3081, 81, 4081
33046-00	Ferrule, 1 in., split 316SS
9310096	Nut, swage, 1 in. 316SS
9210012	Buffer solution, 4.01 pH, 16 oz
9210013	Buffer solution, 6.86 pH, 16 oz
9210014	Buffer solution, 9.18 pH, 16oz
R508-160Z	ORP solution, 460 mv $\pm$ 10 at 20°C
9550167	EPDM O-ring for Process Connector (PN 23166-00 or 23166-01)
12707-00	Jet Spray Cleaner

NOTE: All accessories above can be used with the Models 396VP, 396RVP, 398VP and 398RVP.

<sup>1</sup> Kynar is a registered trademark of Elf Atochem North American, Inc.

<sup>2</sup> Teflon is a registered trademark of E.I. du Pont de Nemours and Company.



*The right people,  
the right answers,  
right now.*

ROSEMOUNT ANALYTICAL  
CUSTOMER SUPPORT CENTER  
1-800-854-8257



ON-LINE ORDERING NOW AVAILABLE ON OUR WEB SITE  
<http://www.raihome.com>

*Specifications subject to change without notice.*



Credit Cards for U.S. Purchases Only.



Emerson Process Management

Liquid Division

2400 Barranca Parkway

Irvine, CA 92606 USA

Tel: (949) 757-8500

Fax: (949) 474-7250

<http://www.raihome.com>

© Rosemount Analytical Inc. 2005

  
**EMERSON**  
Process Management