

5. Troubleshooting



Warning: Only qualified personnel should attempt to test this instrument. The operator assumes all responsibilities for safe practices while troubleshooting.



Caution: The flow transmitter contains electrostatic discharge (ESD) sensitive devices. Use standard ESD precautions when handling the flow transmitter. See Chapter 2, Installation, for ESD details.

Introduction

In new or re-calibrated instruments, operating problems are most often caused by an improper installation. Review the information on instrument installation in Chapter 2 to verify correct mechanical and electrical installation.

Troubleshooting is more effective if the operation of the equipment is understood before trying to solve the equipment problems. Be familiar with the way the instrument operates (Chapter 3) before troubleshooting an instrument that does not function properly.

Replacement parts must be of the same part type and number. Therefore, contact the FCI Customer Service Department for the correct replacement parts.

Damage to the equipment due to negligence or lack of technician skill is not covered by the warranty, or is damage to flow transmitter caused by part replacement in the field. When parts are replaced, the verification and calibration procedures should be performed by a qualified technician to ensure the accuracy and calibration of the instrument.

Troubleshooting Equipment

Digital Multi-Meter (DMM) (at least 4 1/2 digits resolution recommended) capable of measuring ohms, milliamperes, and volts AC and DC.

Precision decade resistance boxes (two needed, however they are optional).

Quick Troubleshooting

At this point simply observe the system setup to verify operation. Use Table 5-1 as a quick check of problems and solutions. More in-depth discussions follow this table.

Table 5-1. Quick Check Troubleshooting

Problem	Solution
No Display	Check the fuses. Verify that S1 is switched to the correct input voltage. Verify correct power is applied. Verify the ribbon cable between the upper and lower circuit boards is solidly connected and the red stripe is at pin 1.
No Display or Dim Display	Adjust potentiometer R1 on the top circuit card. If there is no change in the display return the potentiometer to the original setting.
Display is Locked Up	Press HOME and then 1 to return to normal operation. Reset the flowmeter by cycling the power.

Table 5-1. Quick Check Troubleshooting (Cont'd)

Problem	Solution
Readings Seem Incorrect	Verify the serial number of the flow element and the flow transmitter are the same number. Verify the flat on the flow element is parallel to the pipe and the flow arrow is pointed in the direction of the flow stream. S2 switches should all be closed for an integral (local) instrument and all open for a remote instrument. Verify all jacks and plugs are all firmly seated and the wiring to them is secure.
If the above solutions do not correct the problem, continue to use the rest of this chapter to troubleshoot.	

In-Depth Troubleshooting - The Flow Element

Check Serial Numbers

Verify that the serial number of the flow element and the flow transmitter are the same. The flow element and the flow transmitter are a matched set and cannot be operated independently of each other. The only exception is when the flow transmitter has been specifically configured to be a replacement.

Check the Resistance of the Flow Element

Use Table 5-2 to determine if the flow element is wired incorrectly or has failed. Turn off the input power to the transmitter. Unplug the flow element at JP3 located on the lower board and measure resistances described below by touching the DMM test leads to the JP3 terminal screws. (Remember to reconnect JP3 back to the flow transmitter when finished.)



Note: If the system does not allow the disconnection of the flowmeter power, or unplugging the flow element, then proceed to the section, "In-Depth Troubleshooting - The Flow Transmitter".

Be sure that pins 2 and 4 are jumpered on the terminal block located in the flow element (local) enclosure. All resistances in Table 5-2 are based on a temperature of 32°F (0 °C). Resistances across the ACT and the REF RTDs for a GF90/92 are approximately 1080 ohms* and for a GF90 high temperature are approximately 110 ohms* at 70 °F (21 °C). The resistances will continue to increase for higher temperatures at the flow element. Check resistance from each pin in the local/remote enclosure to case ground. There should be an infinite resistance. The numbers in Figure 5-1 have been added to the wire designations for discussion purposes and are not found on the JP3 terminal plug or wires.

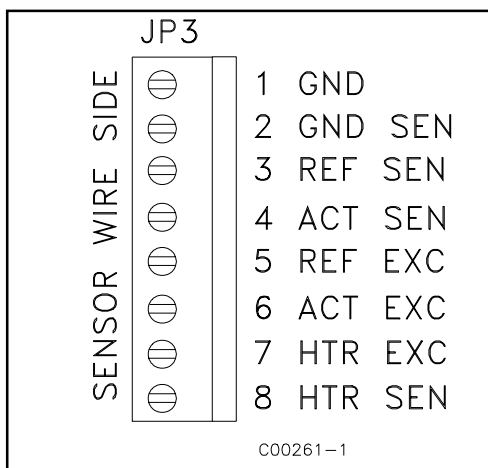

Figure 5-1. JP3 Terminal Plug

Table 5-2. Resistances at JP3 Terminal Plug (GF90/GF92)

Pin Number	Approximate Resistance
1 to 2	0 Ohms
2 to 3	1000 Ohms*
2 to 4	1000 Ohms*
2 to 5	1000 Ohms*
2 to 6	1000 Ohms*
2 to 7	220 Ohms
2 to 8	220 Ohms

***For the GF90 high temperature flow element divide by 10.**

If the measured resistances correspond to Table 5.2 then the flow element is functioning properly. The problem lies elsewhere. Skip the rest of this section and proceed with the section, In-Depth Troubleshooting - The flow transmitter. If the measured values do not correspond to Table 5-2 then a problem exists in the flow element. For remote instruments, with a cable between the flow element and the flow transmitter, the cable could be shorted or open. To isolate a problem with the cable, check the flow element resistances at the terminal block located within the flow element (local) enclosure. Disconnect the wires from the terminal block and measure resistances described below by touching the DMM test leads to the terminal block screws. The measured resistances should correspond approximately to the values in Table 5-3.

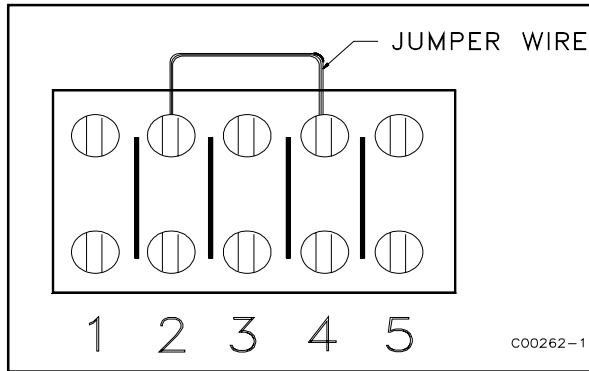

Figure 5-2.
Flow Element Enclosure Terminal Block

Table 5-3.
Resistance at Flow Element Enclosure Terminal Block

Terminal No.	Approximate Resistance
1 to 4	220Ω
2 to 4	0Ω
3 to 4	1000Ω*
5 to 4	1000Ω*

*For GF90HT divide by 10.

If the measured resistances correspond to Table 5-3 then the cable or wiring is defective. If the measured values do not correspond to Table 5-3 then the Flow Element is defective. Contact customer service for details on how to obtain another cable or flow element.

In-Depth Troubleshooting - The Flow Transmitter

Check the Voltages Across the RTD Leads

This is done without disconnecting any flow element wires. Voltage measurements can be made at JP3 located on the lower circuit board. Measure voltages described below by touching the DMM test leads to the terminal screws. The expected voltages are given in Table 5-4. Refer to Figure 5-1 for pin numbers.

Table 5-4. Voltage Readings in Volts DC at JP3

Pin Number	Approximate Voltage GF90	Approximate Voltage GF90 High Temperature	Approximate Voltage GF92
1 to 2	0	0	0
2 to 3	1.1	0.25	1.1
2 to 4	1.2	0.27	1.2
2 to 5	1.1	0.25	1.1
2 to 6	1.2	0.27	1.2
2 to 7	16.5	16.5	11.4
2 to 8	16.5	16.5	11.4

If the measured voltages correspond to Table 5-4 then the power supplied to and the signals returning from the flow element are correct. The problem is most likely a corrupted calibration parameter. Continue troubleshooting at the next section. If the measured values do not correspond to Table 5-4 and the flow element was proven to function correctly (see previous section), then the flow transmitter is defective. If the previous section checks were not possible and the above values did not correspond, then the problem could be in the flow element or the flow transmitter. Contact Customer Service for details on how to obtain replacements.

Verify the Calibration Parameters

The flowmeter uses a set of predetermined calibration parameters. Most of these parameters cannot change. A data page entitled "GF Series Delta R Data Sheet" is located in the back of this manual. It contains the calibration parameters set in the flow transmitter at the factory. (See the Appendix for a description of these parameters.) Verify that these parameters have not changed using the steps describe below.

1. Identify the appropriate "Delta R" data sheet by serial number. Determine the current group number the flow transmitter by viewing the "Normal Operation" display window. Make sure the current group number corresponds to the group number on the data sheet.
2. Press Home, 5, 1 to enter the "Verify All" function. Verify all calibration parameters listed in the first two columns on the data sheet. Note any differences in values.
3. Press Home, 5, 8 to enter the "Verify Calibration" function. Verify all calibration parameters listed in the second two columns on the data sheet. Note any differences in values.

If any of the parameters have changed, please contact Customer Service. If the parameters have not changed the problem lies elsewhere. Continue with the next section.

In-Depth Troubleshooting - The Installation

Verify Proper Orientation

The flow element must be oriented as described on the "Instrument Information Sheet" located in the back of this manual. Verify that the flat on the flow element is parallel to the pipe and the flow arrow is pointed in the direction of the flow stream. Improper orientation will cause an indeterminate amount of error in the flow measurement. See Chapter 2 for instructions on proper installation.

Verify Proper Insertion Depth

The flow element's thermowells must be located at the center line of the pipe unless the factory specifies otherwise. Improper insertion depth will cause an indeterminate amount of error in the flow measurement. See Chapter 2 for instructions on proper installation.

In-Depth Troubleshooting - The Process

Verify Standard versus Actual Process Conditions

The flowmeter measures the mass flow rate. The mass flow rate is the mass of the gas flowing through a pipe per time. Other flowmeters, such as an orifice plate or a pitot tube, measure the volumetric flow rate. The volumetric flow rate is the volume of gas per time. If the readings displayed by the GF series flowmeters do not agree with another instrument, some calculations may be necessary before comparing them. To calculate the mass flow rate, the volumetric flow rate, and the pressure and temperature at the point of measurement must be known. Use the following equation to calculate the mass flow rate (standard volumetric flow rate) for the other instrument.

Equation:

$$Q_s = Q_A \times \frac{P_A}{T_A} \times \frac{T_s}{P_s}$$

Where:

Q_A = Volumetric Flow Q_s = Standard Volumetric Flow
 P_A = Actual Pressure T_A = Actual Temperature
 P_s = Standard Pressure T_s = Standard Temperature
 and Pressure and Temperature are in absolute units.

Example:

$$\begin{array}{ll} Q_A = 1212.7 \text{ ACFM} & Q_S = 1485 \text{ SCFM} \\ P_A = 19.7 \text{ PSIA} & T_A = 120^\circ\text{F} (580^\circ\text{R}) \\ P_S = 14.7 \text{ PSIA} & T_S = 70^\circ\text{F} (530^\circ\text{R}) \end{array}$$

$$\frac{1212.7 \text{ ACFM}}{1} \frac{14.7 \text{ PSIA}}{19.7 \text{ PSIA}} \frac{530^\circ\text{R}}{580^\circ\text{R}} = 1485 \text{ SCFM}$$



Note: The rated outputs of fans, blowers or compressors cannot be accurately compared to the flow rate output of the GF series flowmeter.

Swirling Flow and the Length of the Meter Section

The GF series flowmeter is calibrated in a non-rotating flow stream with the streamline parallel to the pipe walls. Rotation of the flow stream or a flow stream that is not parallel to the pipe walls may cause flow measurement errors. A straight pipe run of 20 pipe diameters upstream and 10 pipe diameters downstream generally produces a desirable flow stream. Elbows, valves, and other obstructions, located close to the GF Series Flowmeter may cause an indeterminate error in the flow rate measurement. If a shorter pipe run distance is needed, a flow conditioner can be installed with the flow element. Contact an FCI representative for more information.

Condensation, Pulsing Flow or Transient Flow

If a component of the process media is near its saturation temperature it is probably condensing on the flow element. Liquid on the flow element will drive the flow measurement higher than actual. The flow element must be placed somewhere else in the process where the flow stream temperature is well above the saturation temperature and below the saturation pressure of any of the process gases.

Pulsing or transient flows will cause the flowmeter measurement to be higher than actual. Compressors, fans, blowers, etc. commonly induce pulsation within the flow stream. The flow element should be located at least 20 diameters downstream and 10 diameters upstream of any compressor, fan or blower.

Transient flow (quick increases or decrease flow rate) may cause an indeterminate amount of error in the flow measurement. The flow rate measurements made during quick changes in flow rate should be discarded.

Natural Convection in Vertical Pipes and Ducts

A long, vertical stand of pipe that has no induced flow may have a circulation of gas caused by free convection. If the flowmeter was calibrated to measure small flow rates the convection current may cause a flow reading. If this is undesirable, move the flow element to another location.

Other Troubleshooting

The Relays

See Chapter 3 for instructions on setting the relays. From the keypad, the relay state can be switched. This can be used to test the interface with the GF series relays.

To test the relays:

1. From the Main menu press 2. The "2.0 PORT SETUP" menu title will appear.
2. Press 2, the "Relay Setup" option.
3. Press 3, for the "Test Relays" option.
4. Pressing 1 or 2 will toggle the states of the respective relays. The present state of the relays are displayed in parenthesis.

The relays toggle between energized and de-energized and the state should be reported in the status line of the "Normal Operation" window. Changing states also cause an audible click.

Verifying Delta R's



Note: Be sure to use the DR table supplied with this flowmeter. Use two decade resistance boxes, and or fixed resistors.

A DR table is supplied with each flowmeter. The table can be used to verify correct operation of the transmitter independent of the flow element by simulating the RTDs' input with precision resistance decade boxes. In order to verify that the flow transmitter is functioning properly, the inputs from the RTDs may be disconnected and precision resistance of known value substituted. Then measure the flow transmitter output (voltage, current, or relay logic switch points) and compare to the Delta R table. Perform the following steps to verify operation.

1. Verify that the serial number of the flowmeter and the serial number of the Delta R Data Sheet are the same before proceeding. If the serial numbers do not match, the Delta R Data Sheet is not applicable. Each flowmeter has a unique Delta R Data Sheet.
2. Verify the Delta R Data Sheet has the appropriate group number.
3. Disconnect JP3 and connect the decade boxes as shown in Figure 5-3.

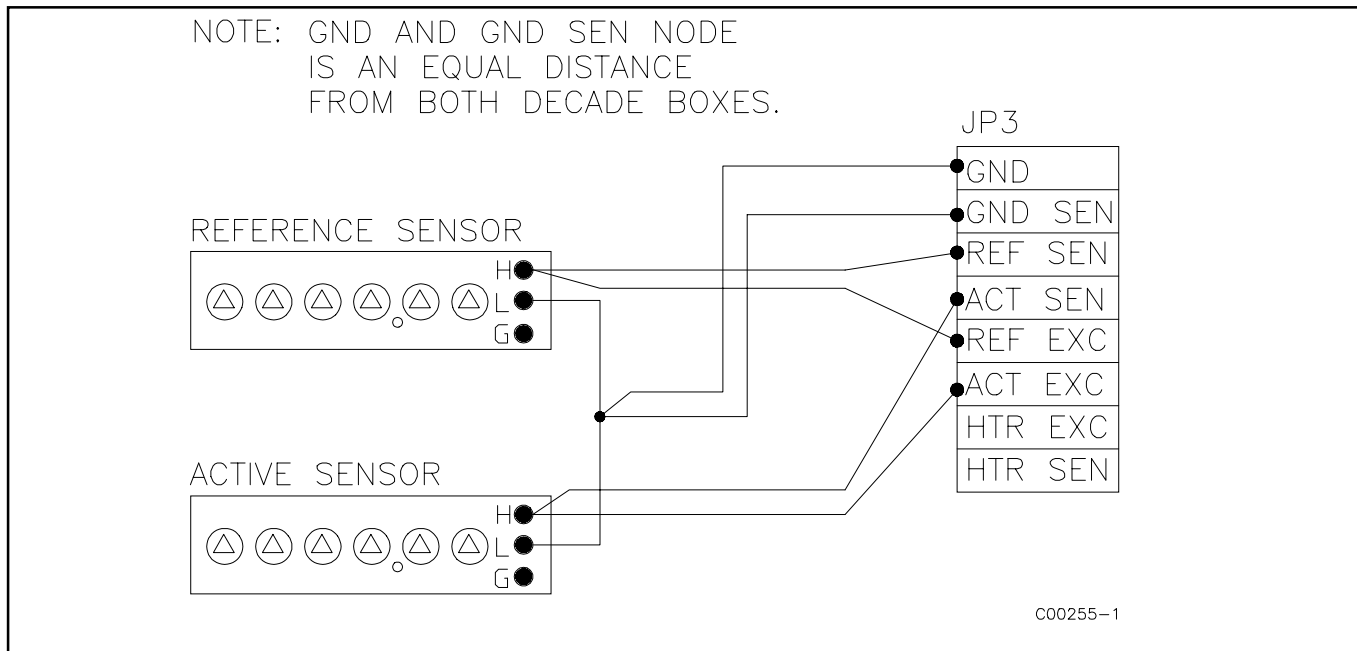

Figure 5-3. Decade Box Connections

4. Set the reference decade box to 100 or 1000 ohms, depending on type of nominal flow element resistance.
5. Set the active decade to the same reading as step 3, plus the DR value from the DR table (i.e. 1000 ohms + 25 ohms = 1025 ohms).
6. For current loop outputs, connect the milliamp meter between the +I OUT (positive lead) and OUT COM (negative lead) on connector terminal JP6 and select a range appropriate for your output current. For the voltage output signals, connect a DMM across the +E OUT and OUT COM on connector terminal JP6.
7. Turn power ON and allow the instrument 10 minutes to stabilize.
8. Be sure the flow transmitter is in the correct group.
9. Increase the decade resistance connected to the active terminal by the value shown in the DR column for the low-limit signal. Set the active decade for a resistance of 1000 ohm or 100 ohm + the DR value. The meter reading should equal the recorded value within $\pm 1\%$ of the full signal range.

Example: 4-20 milliampere Output Signal = 1% of 16 milliampere = 0.16 milliampere = Tolerance.

10. Repeat step 7 for the other flow rates in the Delta R Table for this flowmeter.
11. Compare results of the verification measurements with the output signal values recorded on the Delta R Data Sheet to determine if the transmitter is functioning properly. Also verify the display reading matches.
12. Turn power OFF and disconnect the decade resistors. Connect the proper wires from the flow element to terminal block.
13. Disconnect the milliamp meter. Connect the output load to the appropriate OUT+ and OUT COM terminals on the lower (I/O/P) board.
14. Close the enclosure, making sure that none of the wires are caught. Ensure that all seals and gaskets are properly installed. If a custom enclosure exists, be sure it is placed back into safe operating condition.

If the readings are good, the flow transmitter is good and problem may involve the flow element. If readings are off, a flow element calibration may be required or the flow transmitter needs to be setup.

Repair



Note: Any unauthorized repair attempts will void the warranty.

At this time FCI does not consider there to be any field-repairable items with the exception of the replacement of fuses F1 and F2. Any repair at the component level for either the flow elements and enclosure or the flow transmitter and attached components is not advised or recommended by FCI.

Contact the authorized FCI field representative (see list of regional territories and the respective agents) or FCI (see telephone and FAX numbers in the front of this manual) to determine the best course of action.

Defective Parts

Before returning any equipment to FCI, obtain a return authorization number (see Appendix C) for authorization, tracking, and repair/replacement instructions. Remove the defective instrument, replace with a spare, calibrate, and return the defective instrument to FCI freight prepaid for disposition.

Spares

FCI typically recommends a flow element and a flow transmitter assembly, depending on how critical the monitoring process is.

Storage Information

Spare parts should be kept above grade and indoors. Keep the instrument dry. Add desiccant and enclose in plastic wrap for extended storage periods. There is no predetermined shelf life; reinspect at six month intervals.

Customer Service

If problems or questions exist regarding the flowmeter, please contact the regional or country authorized FCI Field Agent (manufacturer's representative). There is an extensive list of these representatives at the front of this manual. If additional technical assistance is required, contact the FCI Customer Service Department at 1 (800) 854-1993 toll free.

Refer to Appendix C for specific customer service policy and procedures.