

Appendix A. Drawings

All dimensions are shown in inches. Brackets [] indicate dimensions in millimeters.

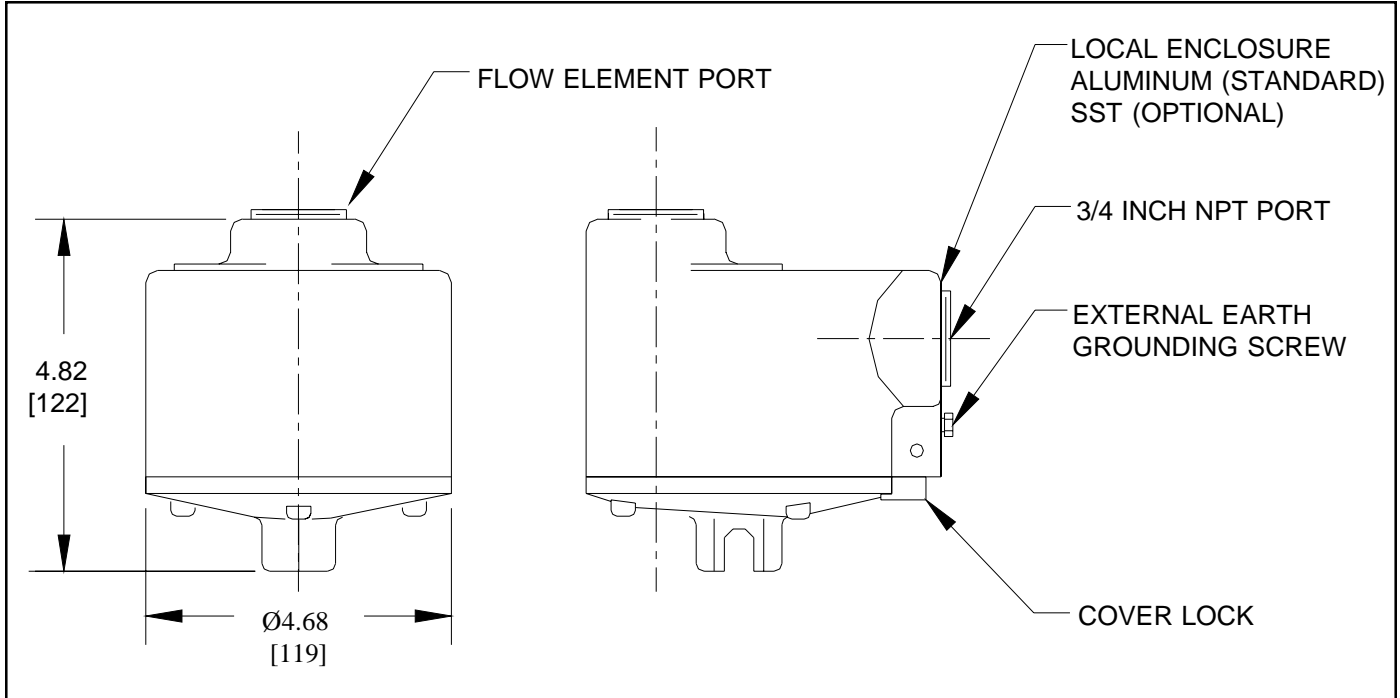

Figure A-1. Local Enclosure, NEMA Type 4X and Hazardous Location (Aluminum Enclosure Shown)

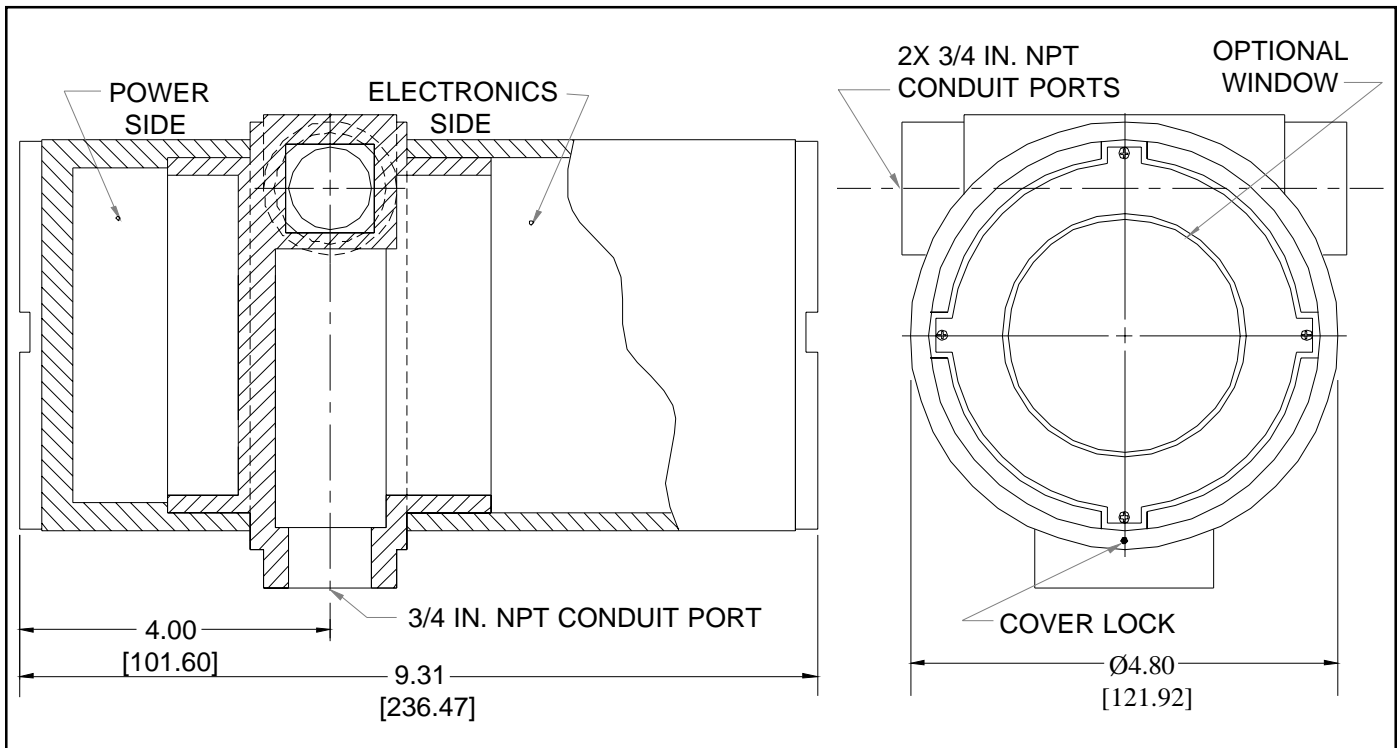

Figure A-2. Remote Aluminum Double Ended Enclosure NEMA 4X and Hazardous Location

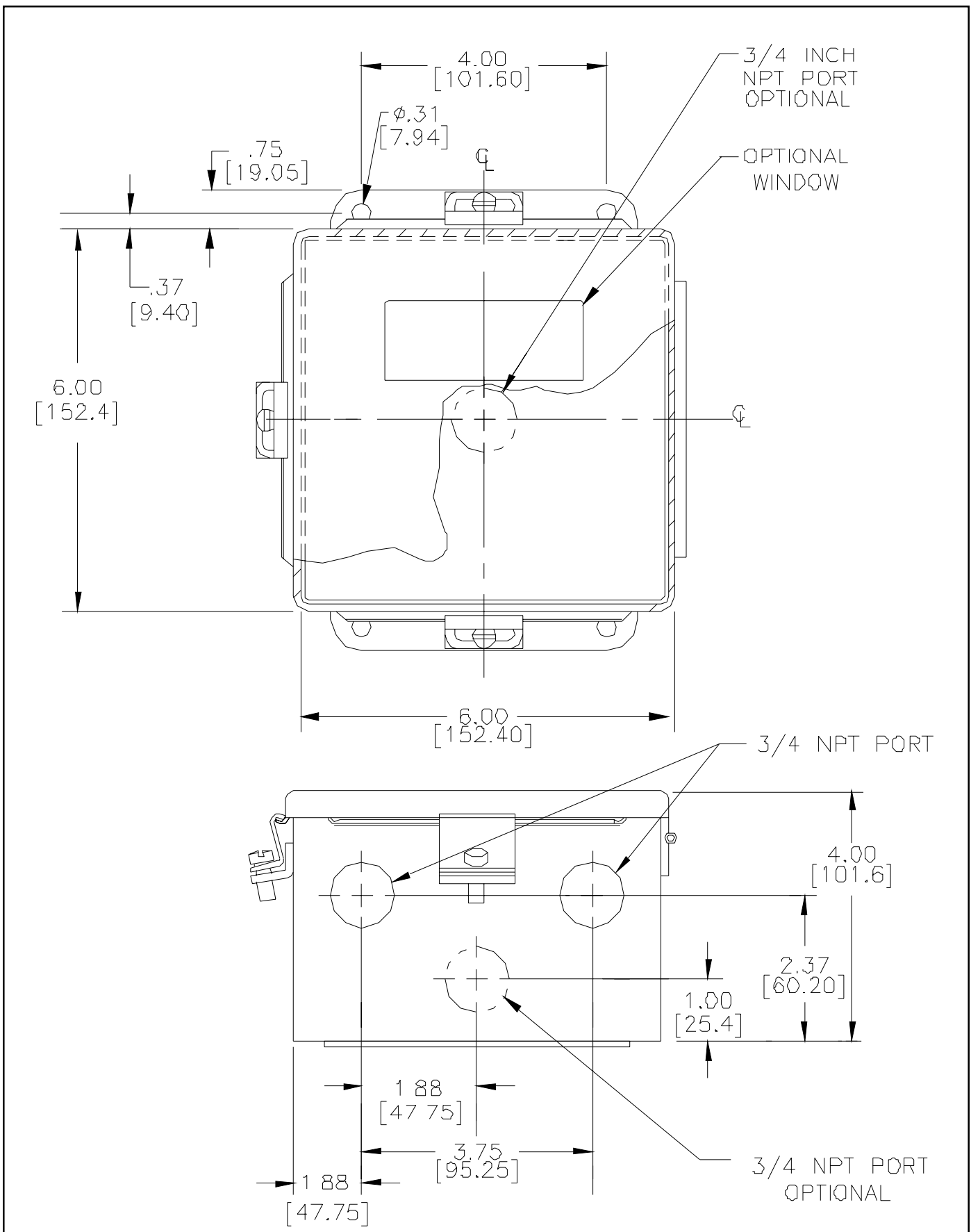

Figure A-3. Remote or Local Enclosure, Carbon Steel

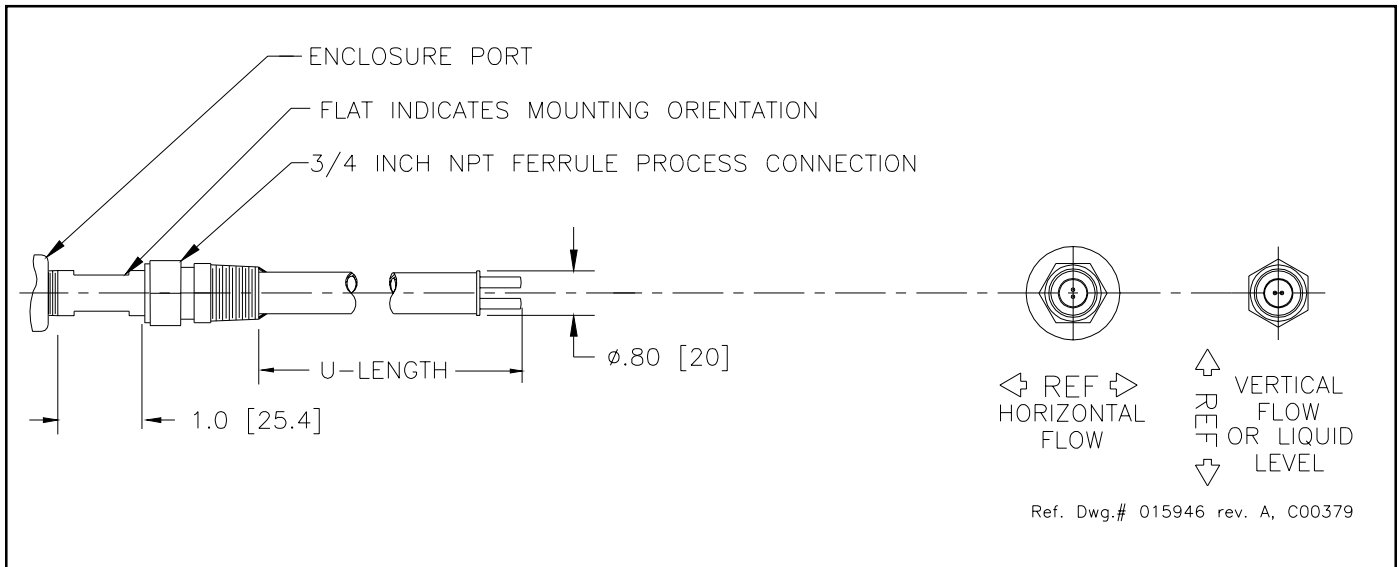

Figure A-4. 3/4 Inch Ferrule NPT Process Connection

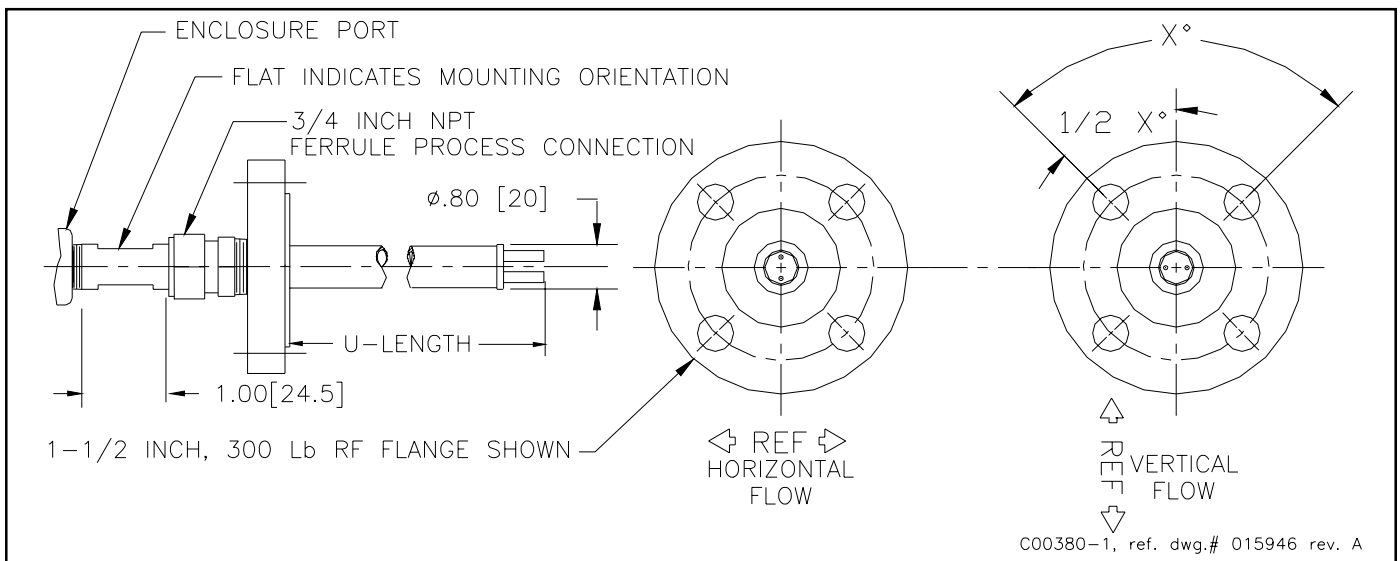

Figure A-5. 3/4 Inch Ferrule NPT With Flange Process Connection

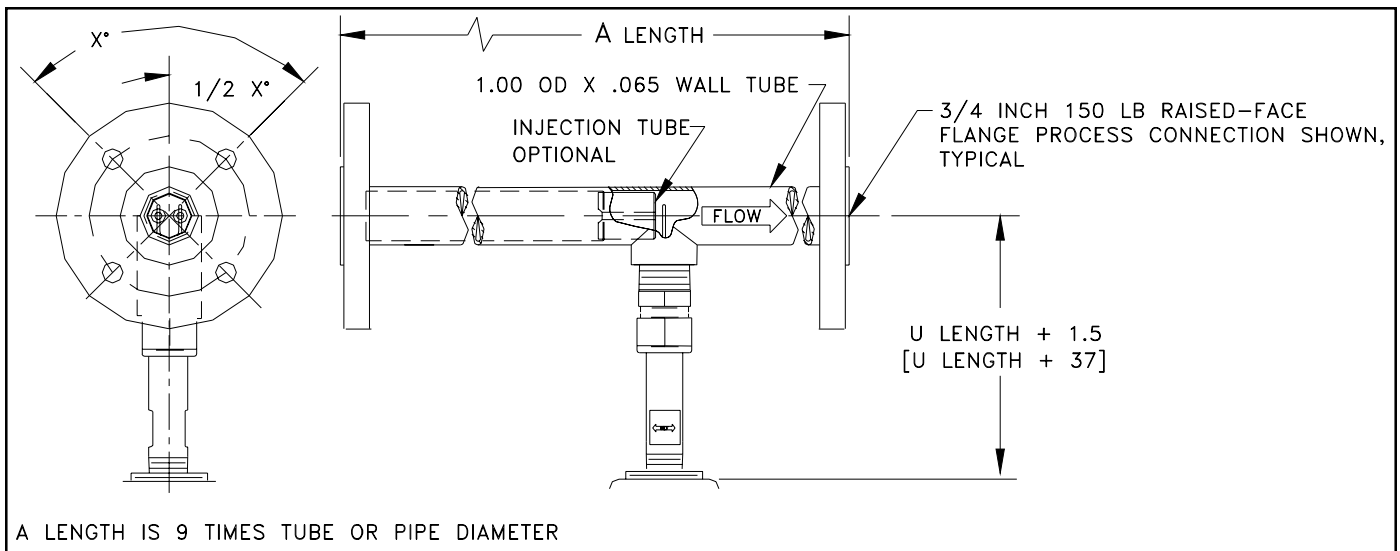

Figure A-6. In-Line Flanged Process Connection

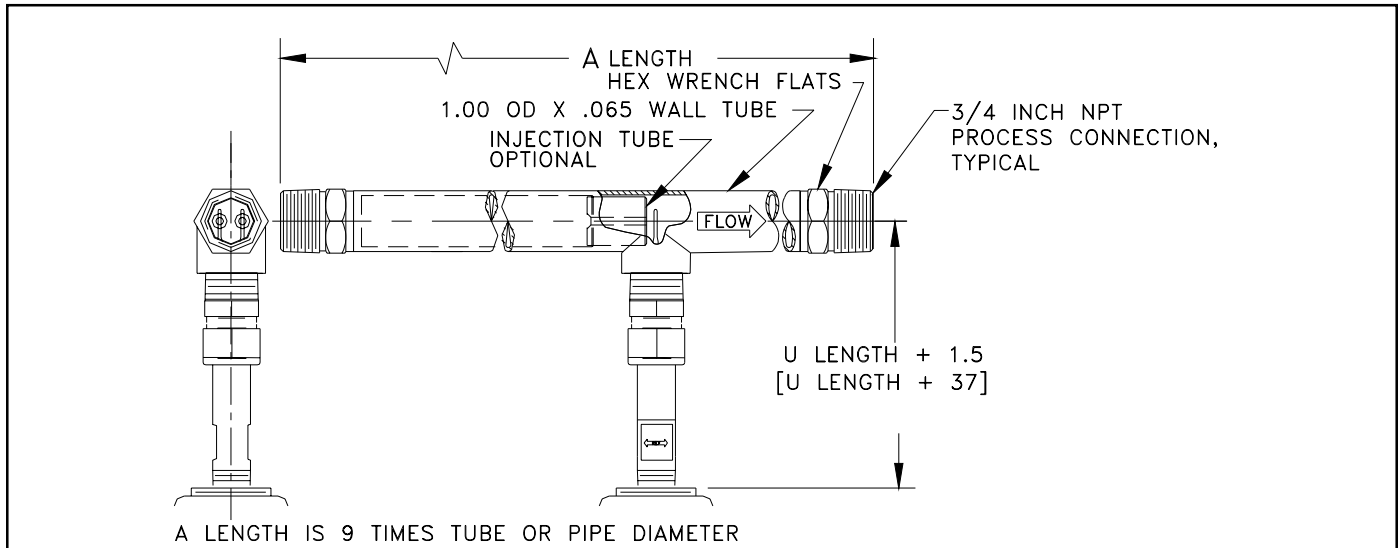

Figure A-7. In-Line NPT Process Connection

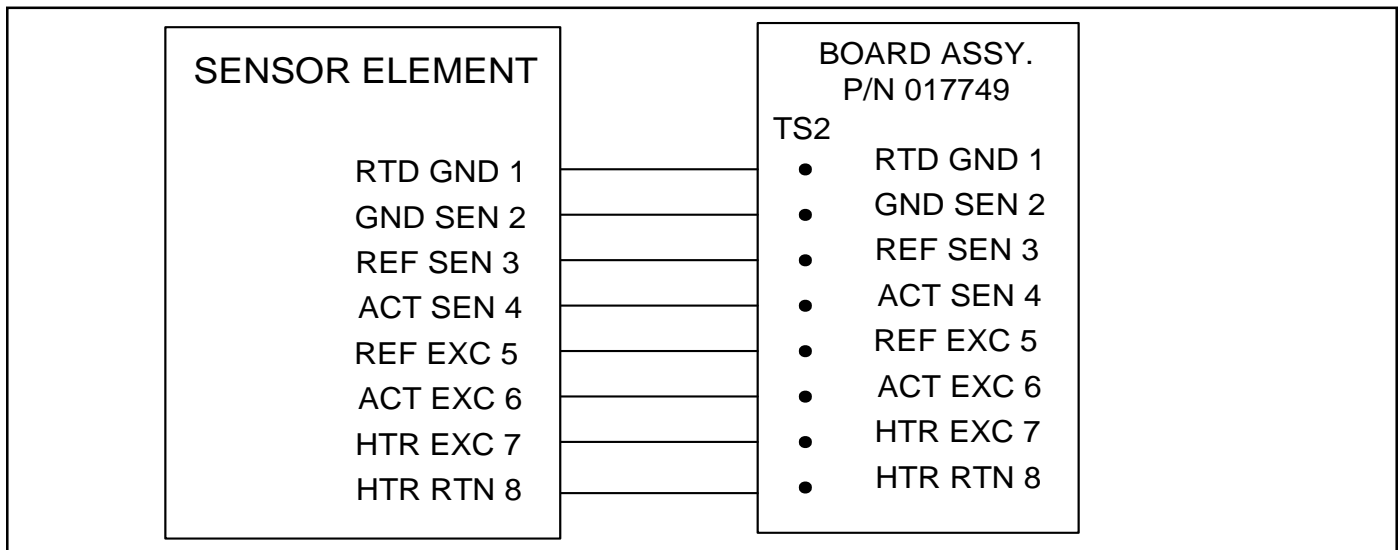

Figure A-8. Integral Option Wiring Diagram

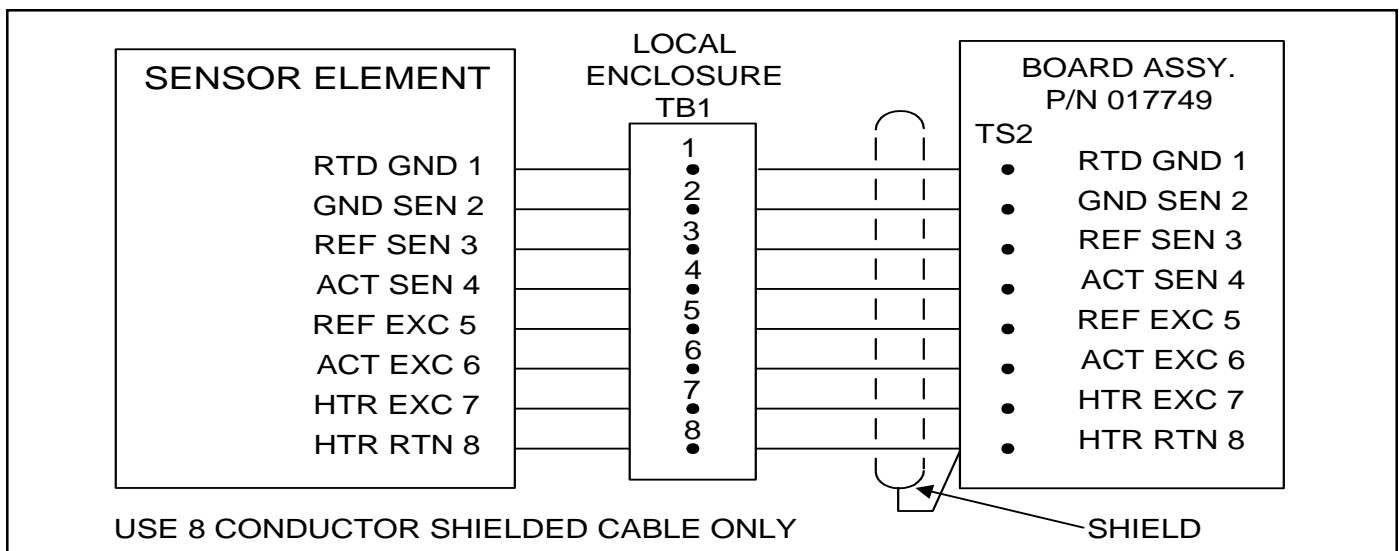

Figure A-9. Remote Wiring Diagram

0.00375 OHMS/OHMS/°C 1000 OHMS PLATINUM**TEMPERATURE VERSUS RESISTANCE**

(Sheet 1 of 3)

T(°F)	OHMS	T(°F)	OHMS	T(°F)	OHMS	T(°F)	OHMS
-40	846.614	3	938.457	46	1029.598	89	1120.046
-39	848.758	4	940.584	47	1031.710	90	1122.141
-38	850.902	5	942.711	48	1033.821	91	1124.236
-37	853.045	6	944.838	49	1035.931	92	1126.330
-36	855.188	7	946.964	50	1038.042	93	1128.424
-35	857.331	8	949.090	51	1040.152	94	1130.517
-34	859.473	9	951.216	52	1042.261	95	1132.610
-33	861.615	10	953.341	53	1044.370	96	1134.703
-32	863.756	11	955.466	54	1046.479	97	1136.795
-31	865.897	12	957.590	55	1048.587	98	1138.887
-30	868.038	13	959.714	56	1050.695	99	1140.978
-29	870.178	14	961.838	57	1052.803	100	1143.069
-28	872.318	15	963.961	58	1054.910	101	1145.160
-27	874.457	16	966.084	59	1057.017	102	1147.250
-26	876.596	17	968.207	60	1059.124	103	1149.340
-25	878.734	18	970.329	61	1061.230	104	1151.429
-24	880.873	19	972.451	62	1063.335	105	1153.518
-23	883.010	20	974.572	63	1065.441	106	1155.607
-22	885.148	21	976.693	64	1067.546	107	1157.695
-21	887.285	22	978.814	65	1069.650	108	1159.783
-20	889.421	23	980.934	66	1071.755	109	1161.870
-19	891.558	24	983.054	67	1073.859	110	1163.957
-18	893.693	25	985.174	68	1075.962	111	1166.043
-17	895.829	26	987.293	69	1078.065	112	1168.129
-16	897.964	27	989.412	70	1080.168	113	1170.215
-15	900.099	28	991.530	71	1082.270	114	1172.300
-14	902.233	29	993.648	72	1084.372	115	1174.385
-13	904.367	30	995.766	73	1086.474	116	1176.470
-12	906.500	31	997.883	74	1088.575	117	1178.554
-11	908.633	32	1000.000	75	1090.676	118	1180.637
-10	910.766	33	1002.117	76	1092.776	119	1182.720
-9	912.899	34	1004.233	77	1094.876	120	1184.803
-8	915.030	35	1006.349	78	1096.976	121	1186.885
-7	917.162	36	1008.464	79	1099.075	122	1188.967
-6	919.293	37	1010.579	80	1101.174	123	1191.049
-5	921.424	38	1012.694	81	1103.272	124	1193.130
-4	923.555	39	1014.808	82	1105.371	125	1195.210
-3	925.685	40	1016.922	83	1107.468	126	1197.290
-2	927.814	41	1019.036	84	1109.566	127	1199.370
-1	929.944	42	1021.149	85	1111.663	128	1201.449
0	932.073	43	1023.262	86	1113.759	129	1203.528
1	934.201	44	1025.374	87	1115.855	130	1205.607

0.00375 OHMS/OHMS/°C 1000 OHMS PLATINUM**TEMPERATURE VERSUS RESISTANCE****(Sheet 2 of 3)**

T(°F)	OHMS	T(°F)	OHMS	T(°F)	OHMS	T(°F)	OHMS
132	1209.762	175	1298.661	218	1386.609	261	1473.427
133	1211.839	176	1300.717	219	1388.641	262	1475.431
134	1213.916	177	1302.773	220	1390.673	263	1477.434
135	1215.992	178	1304.829	221	1392.705	264	1479.436
136	1218.068	179	1306.884	222	1394.736	265	1481.438
137	1220.143	180	1308.939	223	1396.766	266	1483.439
138	1222.218	181	1310.993	224	1398.795	267	1485.439
139	1224.293	182	1313.047	225	1400.824	268	1487.439
140	1226.367	183	1315.100	226	1402.853	269	1489.437
141	1228.440	184	1317.152	227	1404.880	270	1491.435
142	1230.513	185	1319.204	228	1406.907	271	1493.432
143	1232.586	186	1321.256	229	1408.934	272	1495.429
144	1234.658	187	1323.307	230	1410.959	273	1497.424
145	1236.730	188	1325.357	231	1412.985	274	1499.419
146	1238.801	189	1327.407	232	1415.009	275	1501.413
147	1240.872	190	1329.456	233	1417.033	276	1503.407
148	1242.942	191	1331.505	234	1419.056	277	1505.399
149	1245.012	192	1333.553	235	1421.079	278	1507.391
150	1247.082	193	1335.601	236	1423.101	279	1509.382
151	1249.151	194	1337.648	237	1425.122	280	1511.372
152	1251.219	195	1339.695	238	1427.142	281	1513.361
153	1253.287	196	1341.741	239	1429.162	282	1515.350
154	1255.355	197	1343.786	240	1431.182	283	1517.338
155	1257.422	198	1345.831	241	1433.200	284	1519.325
156	1259.488	199	1347.875	242	1435.218	285	1521.311
157	1261.554	200	1349.919	243	1437.235	286	1523.296
158	1263.620	201	1351.962	244	1439.252	287	1525.281
159	1265.685	202	1354.005	245	1441.268	288	1527.264
160	1267.750	203	1356.047	246	1443.283	289	1529.247
161	1269.814	204	1358.089	247	1445.298	290	1531.229
162	1271.878	205	1360.130	248	1447.311	291	1533.210
163	1273.941	206	1362.170	249	1449.324	292	1535.191
164	1276.003	207	1364.210	250	1451.337	293	1537.170
165	1278.066	208	1366.249	251	1453.349	294	1539.149
166	1280.127	209	1368.288	252	1455.360	295	1541.127
167	1282.189	210	1370.326	253	1457.370	296	1543.104
168	1284.249	211	1372.363	254	1459.380	297	1545.080
169	1286.310	212	1374.400	255	1461.389	298	1547.056
170	1288.369	213	1376.436	256	1463.397	299	1549.030
171	1290.429	214	1378.472	257	1465.404	300	1551.004
172	1292.487	215	1380.507	258	1467.411	301	1552.977
173	1294.546	216	1382.541	259	1469.417	302	1554.948
174	1296.603	217	1384.575	260	1471.422	303	1556.919

0.00375 OHMS/OHMS/°C 1000 OHMS PLATINUM**TEMPERATURE VERSUS RESISTANCE****(Sheet 3 of 3)**

T(°F)	OHMS
304	1558.890
305	1560.859
306	1562.827
307	1564.795
308	1566.761
309	1568.727
310	1570.692
311	1572.656
312	1574.619
313	1576.581
314	1578.542
315	1580.502
316	1582.462
317	1584.420
318	1586.378
319	1588.334
320	1590.290
321	1592.245
322	1594.198
323	1596.151
324	1598.103
325	1600.054
326	1602.004
327	1603.953
328	1605.901
329	1607.848
330	1609.794
331	1611.739
332	1613.683
333	1615.626
334	1617.568
335	1619.509
336	1621.449
337	1623.388
338	1625.326
339	1627.263
340	1629.200
341	1631.135
342	1633.069
343	1635.002
344	1636.933
345	1638.864
346	1640.794
347	1642.723
348	1644.651
349	1646.577
350	1648.503